

| NO. | 品名      | Part Name               | Material           | Process・Remark        |
|-----|---------|-------------------------|--------------------|-----------------------|
| 1   | パイプ取付金具 | Attachment Pipe Bracket | Aluminium die cast | Coating (i-PRO white) |

Connect to WV-X6533LN

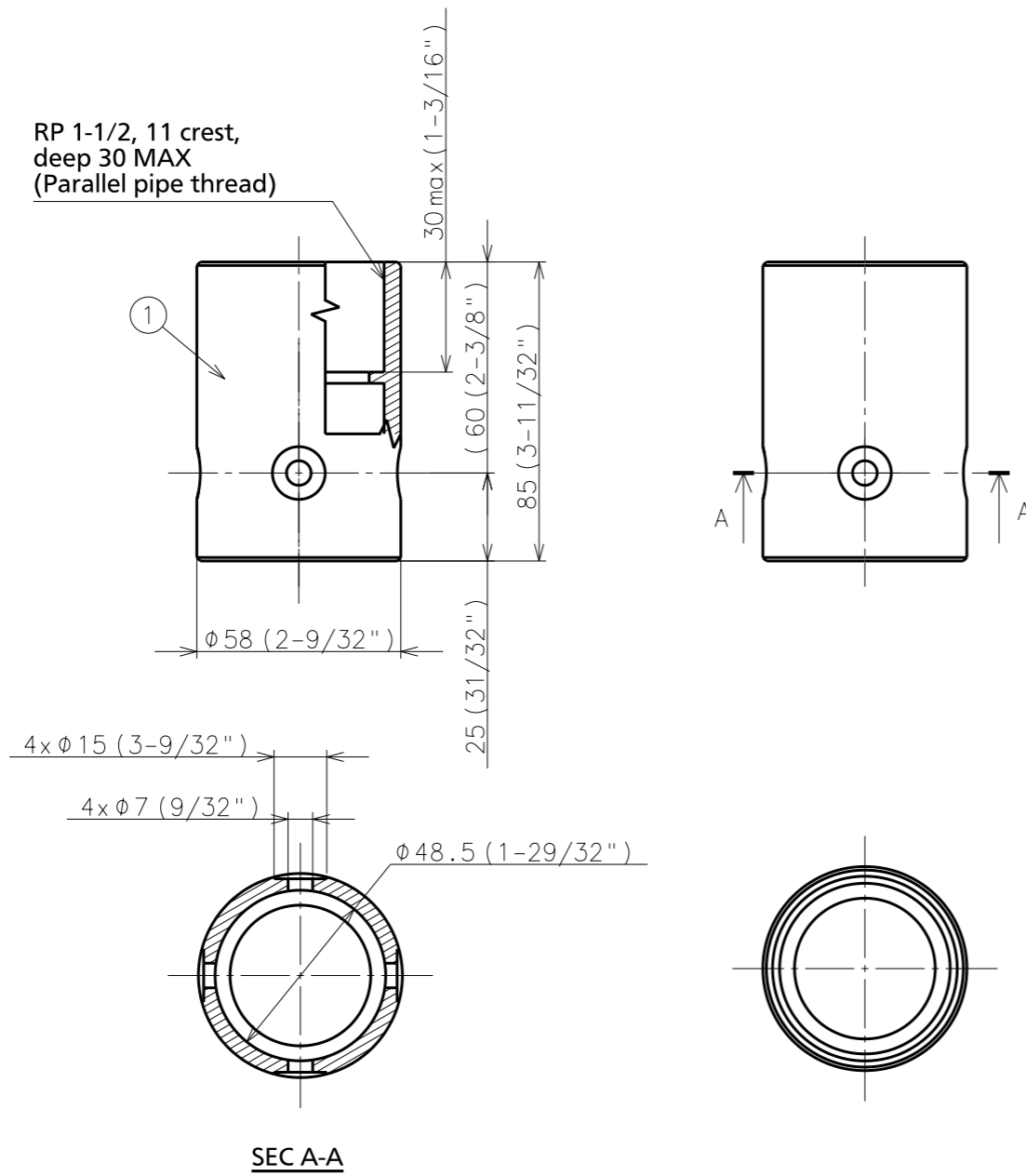

|               |                        |
|---------------|------------------------|
|               | 投影面積 (Projected area)  |
| 側面図/Side-view | 0.00493 m <sup>2</sup> |

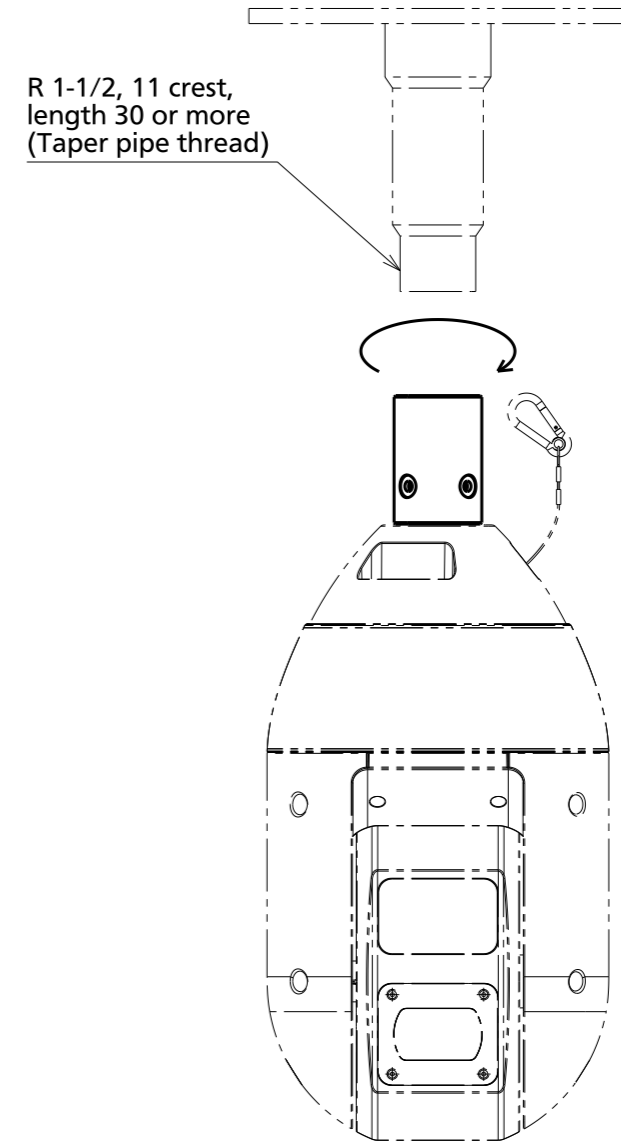

|               |                       |
|---------------|-----------------------|
|               | 投影面積 (Projected area) |
| 側面図/Side-view | 0.083 m <sup>2</sup>  |

注) WV-X6533LNを必ず  
Note) Include WV-X6533LN

Weight : Approx. 200g {0.73 lbs}

WV-QAT500-W (WV-QAT500-WUYS)