

Panasonic

Installation Guide

Included Installation Instructions

Network Camera

Model No. WV-S1570L

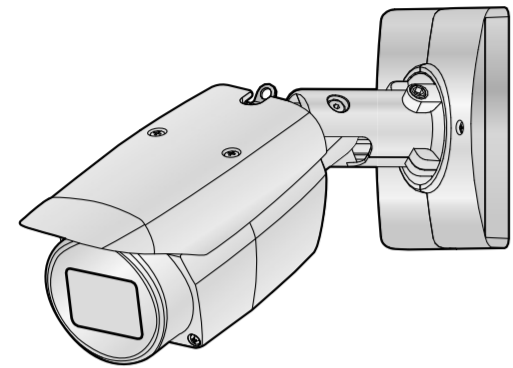

- Before attempting to connect or operate this product, please read these instructions carefully and save this manual for future use.
- For information about the basic description of this product, refer to the Important Information on the provided CD-ROM. For information about how to perform the settings and how to operate the camera, refer to the Operating Instructions on the following Panasonic support website. <https://security.panasonic.com/download/>
- Before reading this manual, be sure to read the Important Information.

For U.S. and Canada:

Panasonic i-PRO Sensing Solutions Corporation of America
800 Gessner Rd, Suite 700 Houston, TX 77024
<https://www.security.us.panasonic.com/>

Panasonic Canada Inc.

5770 Ambler Drive, Mississauga, Ontario, L4W 2T3 Canada
1-877-495-0580
<https://www.panasonic.com/ca/>

For Europe and other countries:

Panasonic Corporation
<http://www.panasonic.com>

Panasonic i-PRO Sensing Solutions Co., Ltd.
Fukuoka, Japan

Authorised Representative in EU:

Panasonic Testing Centre
Panasonic Marketing Europe GmbH
Winsbergring 15, 22525 Hamburg, Germany



© Panasonic i-PRO Sensing Solutions Co., Ltd. 2019

Ns0419-1109 PGQX2293YA Printed in China

Important safety instructions

- 1) Read these instructions.
 - 2) Keep these instructions.
 - 3) Heed all warnings.
 - 4) Follow all instructions.
 - 5) Do not block any ventilation openings. Install in accordance with the manufacturer's instructions.
 - 6) Do not install near any heat sources such as radiators, heat registers, stoves, or other apparatus (including amplifiers) that produce heat.
 - 7) Only use attachments/accessories specified by the manufacturer.
 - 8) Use only with the cart, stand, tripod, bracket, or table specified by the manufacturer, or sold with the apparatus. When a cart is used, use caution when moving the cart/apparatus combination to avoid injury from tip-over.
- 
- 9) Unplug this apparatus during lightning storms or when unused for long periods of time.
 - 10) Refer all servicing to qualified service personnel. Servicing is required when the apparatus has been damaged in any way, such as power-supply cord or plug is damaged, liquid has been spilled or objects have fallen into the apparatus, the apparatus has been exposed to rain or moisture, does not operate normally, or has been dropped.

Troubleshooting

Before requesting service, refer to "Troubleshooting" of Important Information in the CD-ROM and Operating Instructions on the Panasonic support website. Then, confirm the trouble.

Open Source Software

- This product contains open source software licensed under GPL (GNU General Public License), LGPL (GNU Lesser General Public License), etc.
- Customers can duplicate, distribute and modify the source code of the software under license of GPL and/or LGPL.
- Refer to the "readme.txt" file on the provided CD-ROM for further information about open source software licenses and the source code.
- Please note that Panasonic shall not respond to any inquiries regarding the contents of the source code.

Caution:

- A READILY ACCESSIBLE DISCONNECT DEVICE SHALL BE INCORPORATED TO THE EQUIPMENT POWERED BY 12 V DC POWER SUPPLY.
- ONLY CONNECT 12 V DC CLASS 2 POWER SUPPLY (UL 1310/CSA 223) or LIMITED POWER SOURCE (IEC/EN/UL/CSA 60950-1).

WARNING:

- To prevent injury, this apparatus must be securely attached to the wall/ceiling in accordance with the installation instructions.
- All work related to the installation of this product should be made by qualified service personnel or system installers.
- The installation shall be carried out in accordance with all applicable installation rules.
- The connections should comply with local electrical code.
- Batteries (battery pack or batteries installed) shall not be exposed to excessive heat such as sunlight, fire or the like.

CAUTION:

- The network camera is only intended for a connection to an ethernet or PoE network without routing to the outside plant.

For Canada
CAN ICES-3(A)/NMB-3(A)

For U.S.A.
The model number and serial number of this product may be found on the surface of the unit. You should note the model number and serial number of this unit in the space provided and retain this book as a permanent record of your purchase to aid identification in the event of theft.

Model No. _____
Serial No. _____

☐ : Direct current symbol



CAUTION
Watch your fingers

Disposal of Old Equipment and Batteries Only for European Union and countries with recycling systems

These symbols on the products, packaging, and/or accompanying documents mean that used electrical and electronic products and batteries must not be mixed with general household waste. For proper treatment, recovery and recycling of old products and used batteries, please take them to applicable collection points in accordance with your national legislation. By disposing of them correctly, you will help to save valuable resources and prevent any potential negative effects on human health and the environment. For more information about collection and recycling, please contact your local authority. Penalties may be applicable for incorrect disposal of this waste, in accordance with national legislation.



Note for the battery symbol (bottom symbol)

This symbol might be used in combination with a chemical symbol. In this case it complies with the requirement set by the Directive for the chemical involved.

For U.S.A.

NOTE: This equipment has been tested and found to comply with the limits for a Class A digital device, pursuant to Part 15 of the FCC Rules. These limits are designed to provide reasonable protection against harmful interference when the equipment is operated in a commercial environment. This equipment generates, uses, and can radiate radio frequency energy and, if not installed and used in accordance with the instruction manual, may cause harmful interference to radio communications. Operation of this equipment in a residential area is likely to cause harmful interference in which case the user will be required to correct the interference at his own expense.

FCC CAUTION: Changes or modifications not expressly approved by the party responsible for compliance could void the user's authority to operate the equipment.

Supplier's Declaration of conformity
Trade name : Panasonic
Model No. : WV-S1570L
Responsible Party :
Panasonic Corporation of North America
Two Riverfront Plaza, Newark, New Jersey
07102-5490
Support Contact : 1-800-528-6747



For U.S.A. and Canada

This device complies with part 15 of FCC Rules and Innovation, Science and Economic Development Canada's licence-exempt RSS(s). Operation is subject to the following two conditions : (1) This device may not cause harmful interference, and (2) this device must accept any interference received, including interference that may cause undesired operation.

Preparations

Other items that are needed (not included)

Prepare the required parts for each installation method before starting the installation. The following are the requirements for the various installation methods.

Installation method	Mounting screw	Description of installation method
Directly mount the camera onto the ceiling or wall ¹ (when there is a space for wiring in the ceiling or the wall)	M5 screws/ 4pcs.	[Type 1]
Mount the camera to a junction box ¹ ● Only use metal junction boxes.	M4 screws/ 4pcs. ²	[Type 2]
Mount the camera onto the ceiling or wall using the adapter box (approx. 510 g {1.13 lbs}) ¹ (when there is no space for wiring in the ceiling or the wall)	M5 screws/ 4pcs.	[Type 3]
Mount the camera with WV-Q188/ WV-Q182 (Pole mount bracket: approx. 1.2 kg {2.65 lbs}, option) or WV-Q189/ WV-Q183 (Corner mount bracket: approx. 1.3 kg {2.87 lbs}, option). ³	M5 screws/ 4pcs.	Refer to the operating instructions of each bracket.

- ¹ To mount the camera onto the ceiling or wall, the safety wire (accessory) must be attached. Have an M6 bolt and nut or anchor (with the minimum pull-out strength of 724 N {163 lbf}) ready for securing the safety wire.
- ² Prepare a M4 screw with a washer with a diameter of 7.5 mm {9/32 inches} to 10 mm {13/32 inches} and a spring washer.
- ³ Four screws (M5) to fix the camera to WV-Q188, WV-Q189, WV-Q182 and WV-Q183 are provided with each bracket. Refer to the operating instructions of each bracket for details on fitting procedures.

IMPORTANT:

- For information about the minimum pull-out strength, refer to our website (<https://security.panasonic.com/support/info/> <Control number:C0120>).
- For the screws or anchor bolts used in the above methods ([Type 1] to [Type 3]), be sure to secure the minimum pull-out strength of 724 N {163 lbf} per screw or anchor bolt.
- Select screws according to the material of the location that the camera will be mounted to. In this case, wood screws and nails should not be used.
- If the mounting location such as plaster board is too weak to support the total weight, the area shall be sufficiently reinforced.

Preparations

[1] Attaching the safety wire.

- ① Pass the safety wire (accessory) through the wire mounting hole in the safety wire lug (accessory).

② Fit the Safety wire lug to the camera.

Recommended tightening torque: 0.59 N·m {0.44 lbf·ft}

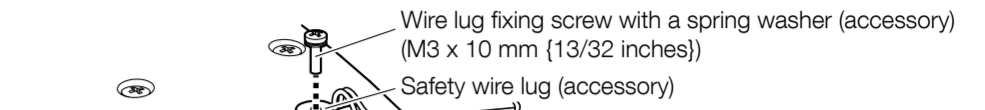

- The safety wire is not shown in the subsequent illustrations.

[2] Remove the front cover. Loosen the four front cover fixing screws and remove the front cover.

IMPORTANT:

- Because the front cover is temporarily removed when installing or adjusting the camera, make sure no liquid enters the camera at these times.

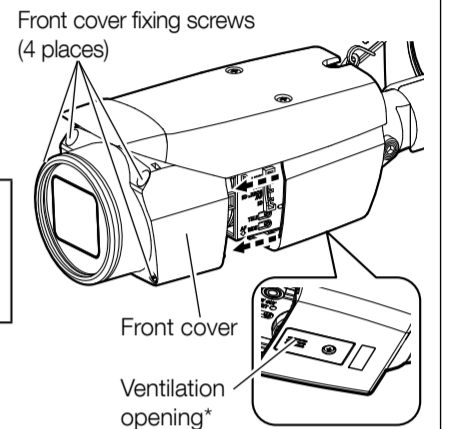

* Do not block the surface as internal humidity is discharged through this ventilation opening. Water does not come inside.

Installation

The installation tasks are explained using 5 steps.

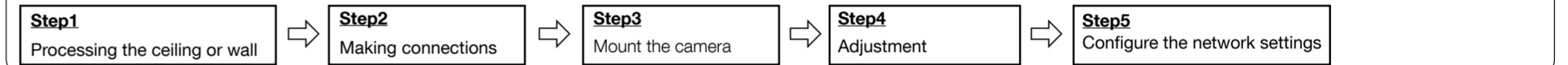

Step 1 Processing the ceiling or wall (There are 3 methods to install the camera to a ceiling or wall.)

[Common]

IMPORTANT:

- Be sure to install the camera at least 2 m 80 cm {9.2 feet} from the ground (the distance between the lowest part of the installed camera and the ground).

- ① Using a 5 mm {3/16 inches} hex wrench (locally procured), loosen the TILT lock screw by about 1 turn until the camera faces downward and then temporarily tighten the TILT lock screw.
- ② Tear off the blue tape attached on camera arm unit.

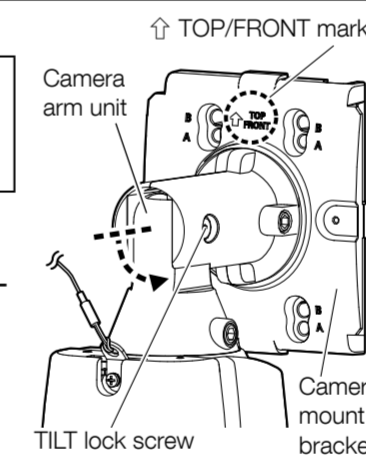

[Type 1] Directly mount the camera onto the ceiling or wall.

Determine the position where the camera is to be mounted on the ceiling or wall and drill a hole for securing the camera and wiring as shown in the illustration to the right.

Determine the diameter and depth of the hole according to the size of fixing screws or anchors (4 pcs.) (M5:locally procured).

Note:

- When installing on a wall, drill a cable access hole closer to the top side.
- When installing on a ceiling, drill a cable access hole so that it comes to closer to the direction in which the camera is pointed.
- When running the cable using the side cable access hole of the camera, the "cable access hole" indicated in the right figure is not required. (For the side cable access hole of the camera, see the figure of ② in [Type 1] of "Step3 Mount the camera".)

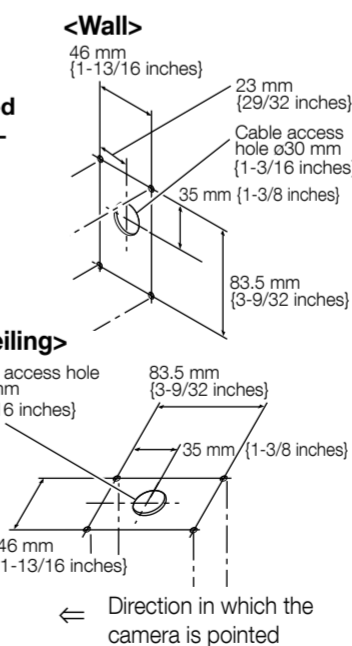

[Type 2] Mount the camera to a junction box.

No operation is required in processing the ceiling or wall.

Note:

- When junction boxes or the like are used, it is recommended that 2 pieces be used side by side. (Securing the camera to one junction box and making connections to the other makes cable connections easy.)

[Type 3] Mount the camera onto the ceiling or wall using the Adapter box (accessory)

The following explains an example of mounting the camera on a wall.

① Secure the adapter box to the wall.

- Drill pilot holes and a cable hole (see the illustration to the right for their dimensions). (Drill pilot holes only if making connections through the cable access hole from the bottom side of the camera.)
- Be sure to face "TOP" inside the adapter box upward.
- Use 4 screws (M5:locally procured) to directly secure the adapter box to the wall. Minimum pull-out strength: 724 N {163 lbf} (per 1 pc.).
- To install this product outdoors, be sure to waterproof the screws and cable access hole.

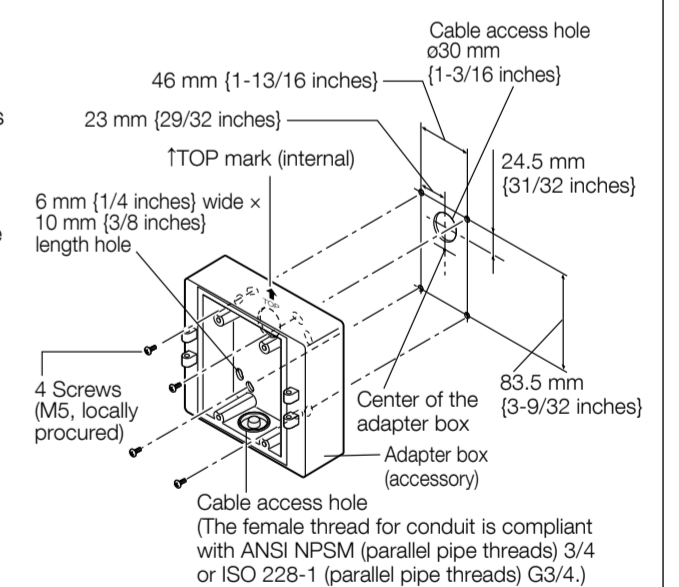

② Temporarily secure the camera mount bracket and camera to the adapter box.

- Use the adapter box mounting screw (M4 x 35 mm {1- 3/8 inches}:accessory) for installing the camera to temporarily install the camera mount bracket to the left or right hinge of the adapter box so that it can be opened and closed.
- Secure the camera mount bracket with "↑ TOP/Front" facing upward.
- When the wall is on one side or the other, install the adapter box to the hinge on the opposite side of the wall.
- Secure the camera mount bracket to the hinge of the adapter box using the following tightening torque. Recommended tightening torque: 0.78 N·m {0.58 lbf·ft}

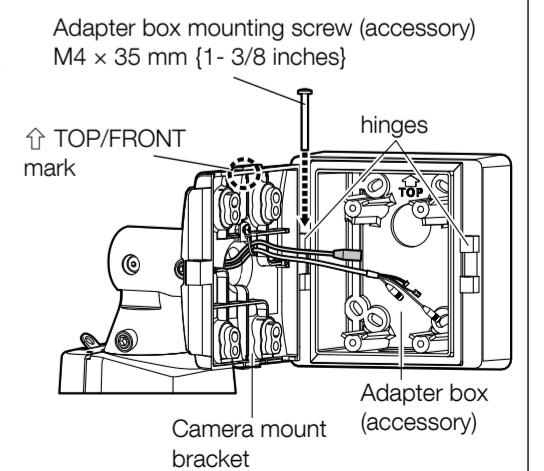

Step2 Making connections

■ Refer to the Important Information on the provided CD-ROM for details about each cable.

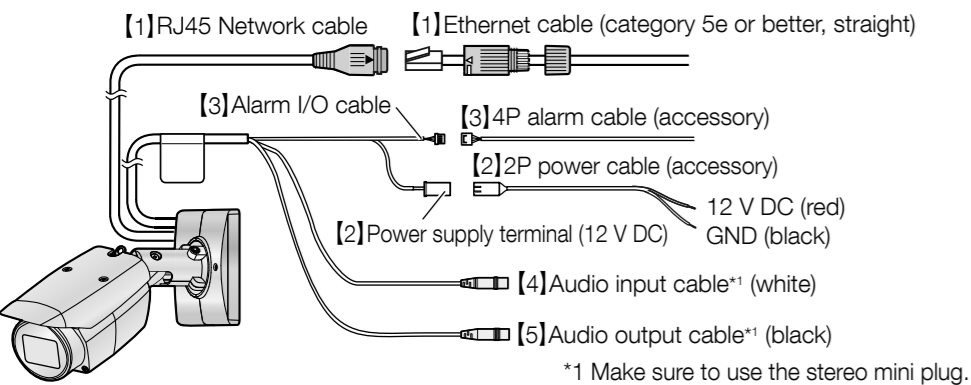

IMPORTANT:

- Turn off each system's power supply (PoE hub or device to supply power to the camera) before making a connection.
- The 12 V DC power supply shall be insulated from the commercial AC power.

[1] Connect an Ethernet cable* (category 5e or better, straight) to RJ45 network cable. * The maximum cable length is 100 m [328 feet].

① First pass the Ethernet cable through the RJ45 waterproof connector cap (accessory) and then through the RJ45 waterproof connector cover (accessory). Next, use a specialized tool (locally procured) to crimp the RJ45 plug (locally procured) to the end of the Ethernet cable.

- Take care not to remove the rubber parts from inside the RJ45 waterproof connector cover.

② Insert the RJ45 plug into the RJ45 waterproof jack connected to the camera.

③ Insert the RJ45 waterproof connector cover so that the "◁: OPEN" mark aligns with the "▶" mark of the RJ45 waterproof jack, and rotate in the direction of the arrow in the illustration at right until matching with the "⇄: LOCK" mark.

④ Connect the RJ45 waterproof connector cap to the RJ45 waterproof connector cover and rotate the RJ45 waterproof connector cap until there is no gap between it and the RJ45 waterproof connector cover.

IMPORTANT:

- If the procedure for the RJ45 waterproof connector (accessory) part is not correctly followed, the waterproofing may be compromised. Do not install the camera where the RJ45 waterproof connector is exposed to constant rain or moisture.

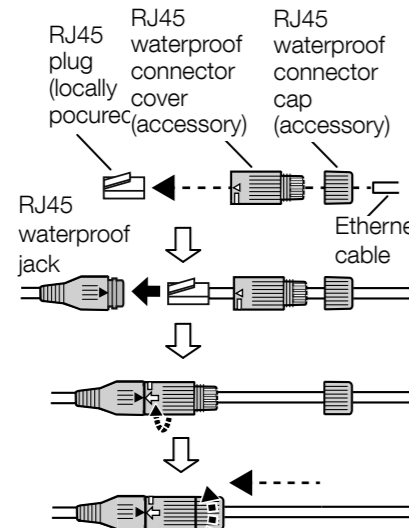

IMPORTANT: (continued)

- The external dimensions of the Ethernet cable are from $\phi 5$ mm ($\phi 3/16$ inches) to $\phi 6.5$ mm ($\phi 1/4$ inches)
- When removing the RJ45 waterproof connector, be sure to loosen the RJ45 waterproof connector cap first, rotate the RJ45 waterproof connector cover in the direction opposite to the attaching direction, and remove it. (If the RJ45 waterproof connector cover is removed when the "⇄: LOCK" mark of the RJ45 waterproof connector cover is aligned with the "▶" mark of the RJ45 waterproof jack, the RJ45 waterproof jack may be damaged).

[2] When connecting an AC adaptor or an external power supply, use the 2P power cable (accessory) to connect it to the camera.

Connect the output cable of the AC adaptor to the 2P power cable (accessory). (Red: 12 V DC side, Black: GND side)

[3] If needed, connect the 4P alarm cable (accessory).

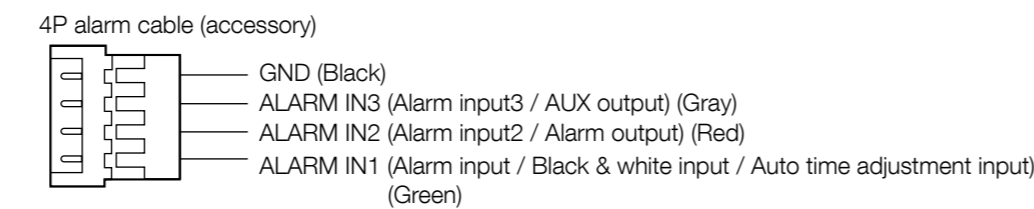

Note:

- The default of EXT I/O terminals are "Off". Refer to the Operating Instructions on the Panasonic support website for further information about the EXT I/O terminal settings.

[4] If needed, connect a microphone or the line out of an external device to the audio input cable.

[5] If needed, connect a powered speaker to the audio output cable.

[6] Adequate waterproof treatment is required for the cables when installing the camera with cables exposed.

The camera body and RJ45 waterproof connector are waterproof, but the cable ends and the internal part of the adapter box (accessory) are not waterproof. When using cables other than Ethernet cables, apply waterproof treatment on each connecting part including disused cables as shown below.

<Waterproof treatment for other cables than the Ethernet cable>

Apply some waterproof tape (accessory) as shown in the right.

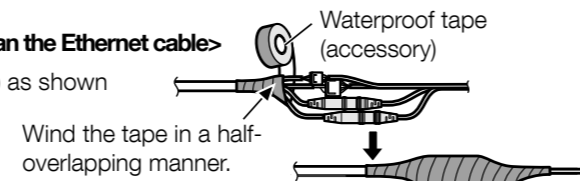

IMPORTANT:

- Stretch the tape by approx. twice (see the illustration) and wind it around the cable. Insufficient tape stretch causes insufficient waterproofing.

Step 4 Adjustment

[1] Change the direction the camera is facing from directly down to facing up and temporarily fix the camera in place.

[2] Fit a pin cable (locally procured) to the MONITOR OUT terminal on the camera and connect an adjustment monitor.

[3] Insert an SD memory card into the SD slot, if necessary. Refer to the "Important Information" on the provided CD-ROM for how to insert/remove the SD memory card.

[4] Turn on the camera.

[5] Adjust the angle of the camera.

① Using a 5 mm {3/16 inches} hex wrench (locally procured), loosen the PAN lock screw on the base of camera arm unit. To direct the camera to the left, turn the camera arm unit clockwise when viewed from the front. To direct the camera to the right, turn it counterclockwise. (Horizontal (PAN) angle: $\pm 180^\circ$)

② Using a 5 mm {3/16 inches} hex wrench (locally procured), loosen the TILT lock screw in the middle of camera arm unit and roughly adjust the direction of the camera. (Vertical (TILT) angle: 0° to 100°)

③ Temporarily tighten PAN lock screw and TILT lock screw to prevent the camera from moving.

④ Using a 5 mm {3/16 inches} hex wrench (locally procured), loosen the YAW lock screw and rotate the camera to adjust the azimuth of the camera. (Azimuth (YAW) angle: -190° to $+100^\circ$)

IMPORTANT:

- Do not touch the TILT rotation unit around the caution label when you change the vertical (TILT) angle to prevent your fingers from being caught.
- Do not adjust the Horizontal (PAN) angle more than $\pm 180^\circ$. This may cause cables to be wrenched.

Note:

- Any of the PAN, TILT and YAW lock screw can be adjusted by loosening them about 1 turn. Do not unscrew them more than necessary.
- Make sure the camera is supported by hand when loosening lock screws and adjusting the direction of the camera.

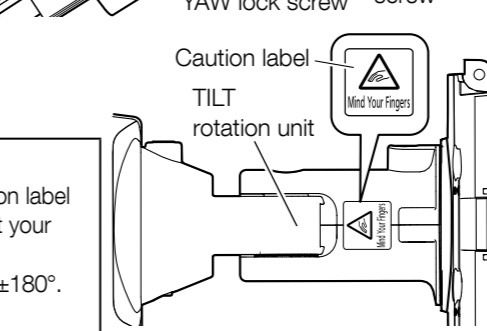
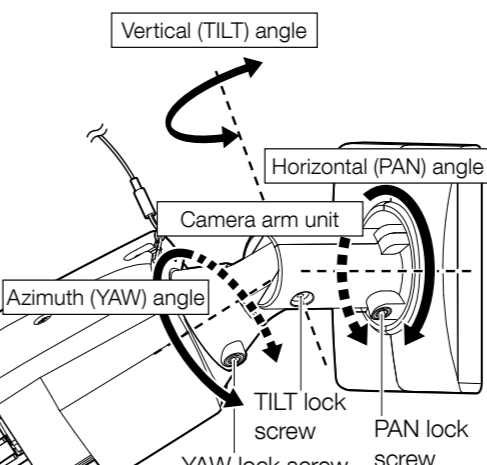
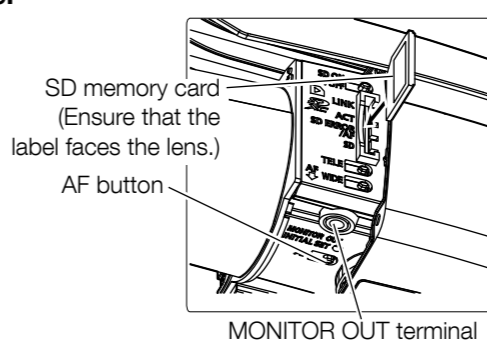

[6] Adjust the zoom and focus.

- Adjust the viewing angle by pressing the WIDE or TELE buttons as shown in the right figure.
- Adjust the focus by pressing the AF (auto focus) button.
- Repeat the process between ① and ② until the size of the image is adjusted to be in the focus. If needed, readjust the angle of the camera, such as Horizontal (PAN) angle, Vertical (TILT) angle, and Azimuth (YAW) angle.

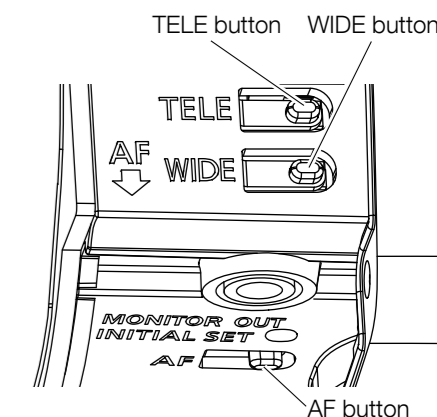

[7] Fix each part by tightening the corresponding lock screw.

Adjust the camera angle and field of view by repeating steps [5] through [6]. When the desired angle and field of view are achieved, fix each part by tightening the corresponding lock screw.

Recommended tightening torque :
PAN lock screw: 2.7 N·m [2.0 lbf·ft]
TILT lock screw: 9.0 N·m [6.6 lbf·ft]
YAW lock screw: 2.7 N·m [2.0 lbf·ft]

[8] Remove a pin cable.

[9] Mount the front cover to the camera, and then fasten it with the 4 fixing screws.

- Recommended tightening torque: 0.59 N·m [0.44 lbf·ft]
- As shown in the right figure, fasten the front cover fixing screws along the diagonal direction.

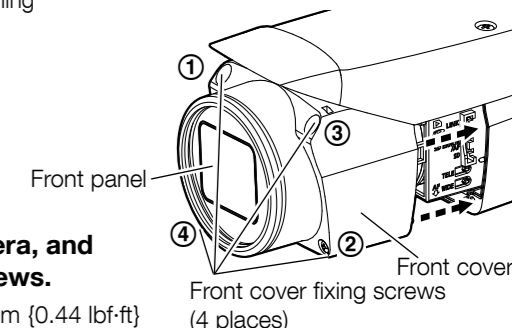

[10] Secure the safety wire (accessory) to the ceiling or wall.

IMPORTANT:

- Each bolt and nut or anchor (M6:locally procured) must have the minimum pull-out strength of 724 N [163 lbf].
- Be sure to secure the safety wire (accessory) to the foundation of a structure or an area that is strong enough.

■ When the camera is installed to the ceiling



■ When the camera is mounted on the wall

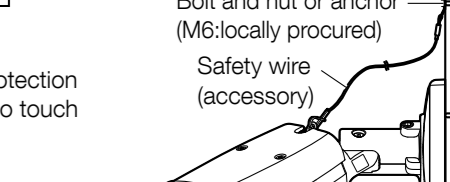

[11] Remove the protection film.

When the camera has been installed, remove the protection film from the front panel. After removal, be sure not to touch the clear part of the front panel.

Step 3 Mount the camera (There are 3 methods to install the camera to a ceiling or wall.)

[Type 1] Directly mount the camera onto the ceiling or wall.

① Use the 2 upper screws (M5:locally procured) to secure the camera.

2 upper screws (M5), Minimum pull-out strength: 724 N [163 lbf] (per 1 pc.). Secure the camera through the holes in side B of the camera mount bracket.

Note:

- When installing on a wall, install the camera mount bracket so that "↑ TOP/FRONT" faces upward.
- When installing on a ceiling, install the camera mount bracket so that "↑ TOP/FRONT" is aligned with the direction in which the camera is pointed.
- To run the cables to the side, pull out the cables from the side cable access hole provided at the side of the camera mount bracket (see the illustration of step ②).

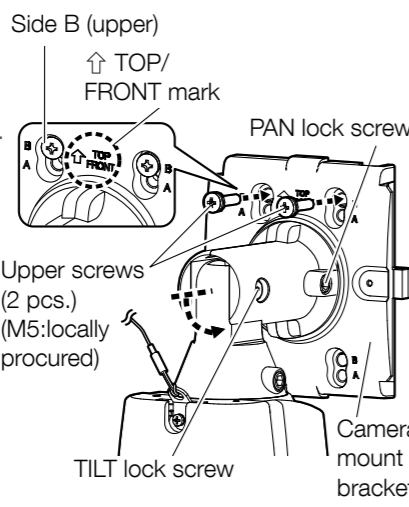

② Loosen the PAN lock screw about 1 turn, tighten the screw temporarily after turning the camera upwards, and then fix the camera with the lower screws (2 pcs.) (M5:locally procured).

Lower screws (2 pcs.) (M5:locally procured), Minimum pull-out strength: 724 N [163 lbf] (per 1 pc.). Secure the camera through the holes in side B of the camera mount bracket.

③ Using the camera mount bracket cover fixing screws (M3x6 mm {1/4 inches}: accessory), install the camera mount bracket cover (accessory) with the camera facing downward.

Recommended tightening torque: 0.59 N·m [0.44 lbf·ft]

Note:

- When wiring cables on the side, use a nipper to cut open a side cable access hole of the camera mount bracket cover, and then pass the cable through.

IMPORTANT:

- To prevent injuries and protect the cables, finish the side cable access hole with a file to avoid sharp edges.

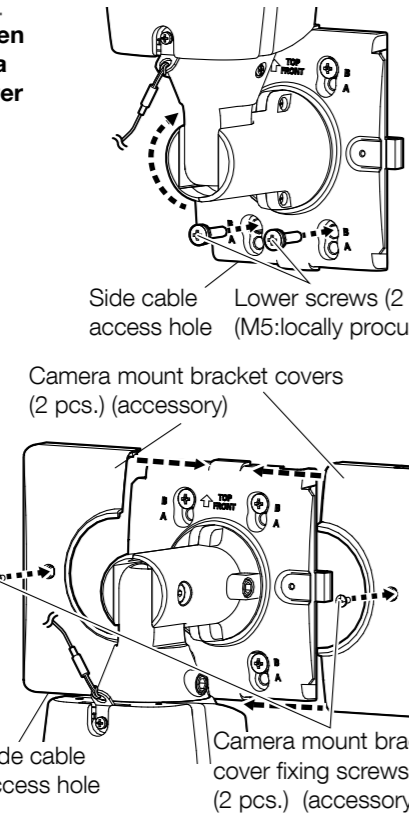

[Type 2] Mount the camera to a junction box.

As shown in the illustration to the lower right, install the camera to a junction box using 4 fixing screws (M4 screw with a washer with a diameter of 7.5 mm {9/32 inches} to 10 mm {13/32 inches} and a spring washer: locally procured) via the holes in side B of the camera mount bracket.

Minimum pull-out strength: 724 N [163 lbf] (per 1 pc.)

Note:

- For installation procedures, refer to step ①, ②, and ③ in [Type 1].

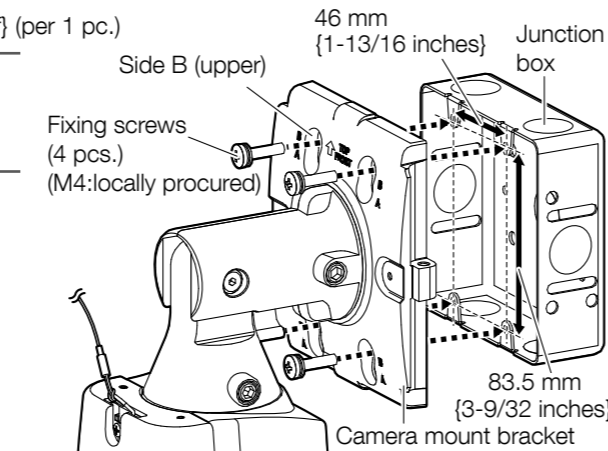

[Type 3] Mount the camera onto the ceiling or wall using the Adapter box (accessory)

The following explains an example of mounting the camera on a wall.

① Using Mounting screws (4 pcs.) (M5 x 20 mm {25/32 inches}: accessory), secure the camera mount bracket to the adapter box via the holes in side A of the camera mount bracket in the order of the top 2 holes to bottom 2 holes.

Recommended tightening torque: 1.86 N·m [1.37 lbf·ft]

Note:

- For installation procedures, refer to step ① and ② in [Type 1].

② Using camera mount bracket cover fixing screws (2 pcs.) (M3 x 6 mm {1/4 inches}: accessory), secure the Camera mount bracket covers (accessory) to the Camera mount bracket.

Recommended tightening torque: 0.59 N·m [0.44 lbf·ft]

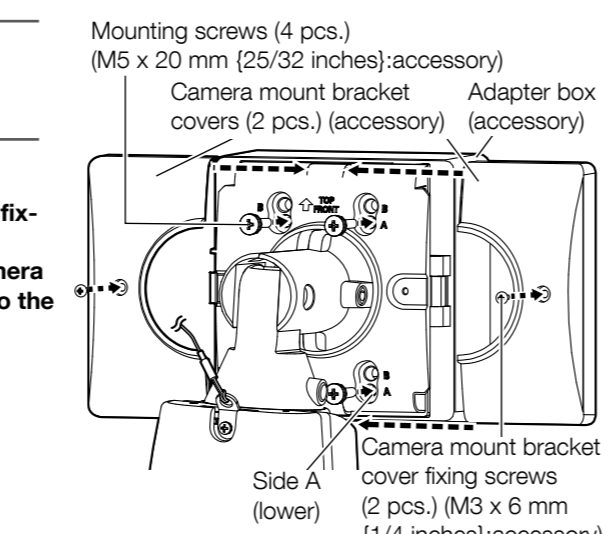

Step5 Configure the network settings

Configure the setting of the camera after temporarily invalidating the firewall software. Once the camera configuration is completed, return to the original state. Contact the network administrator or your Internet service provider for information about configuring the settings of the network.

[1] Insert the provided CD-ROM into the CD-ROM drive of your PC.

The License Agreement will be displayed. Read the Agreement and choose "I accept the term in the license agreement", and click [OK].
⇒ The launcher window will be displayed.

Note:

- If the launcher window is not displayed, double click the "CDLauncher.exe" file on the CD-ROM.
- Refer to "Using the CD-ROM" in the Operating Instructions on the Panasonic support website for further information about CDLauncher

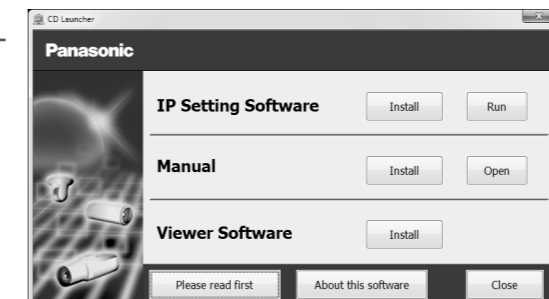

[2] Click the [Run] button next to [IP Setting Software].

⇒ [Panasonic IP Setting] screen will be displayed.

The MAC Address / IP address of the detected camera will be displayed.

[3] Select the camera you want to configure (①), and click [Network Settings] (②) to change the network settings. Then, click [Access Camera] (③).

Note:

- Select the camera with same MAC address as the MAC address printed on the camera that you want to configure.

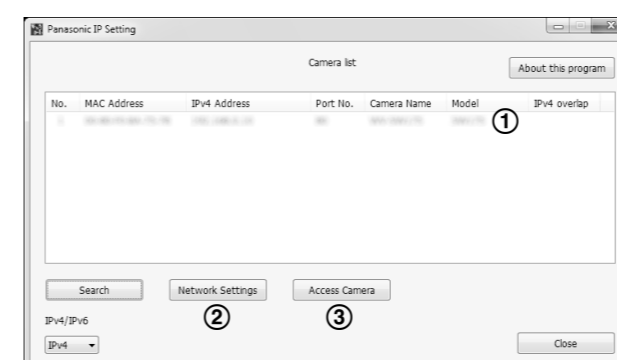

[4] When the administrator registration window is displayed, enter "User name", "Password" and "Retype password" by following the instructions displayed on the screen, and then click the [Set] button.

Please keep your user name and password in a safe place free from public view to ensure security. After completing the registration, the camera will automatically be re-connected and the authentication window will be displayed. Enter the registered user name and password. The default setting of user authentication is "On". For further information, refer to the "Preface" section in the Operating Instructions.



IMPORTANT:

- When the camera is used over the Internet, setting user authentication to "Off" may lead to unintended access by a third party. Please leave user authentication set to "On".

[5] When live images from the camera are displayed, the network connection is complete.

Note:

- For more information on the following content, refer to the Operating Instructions.
 - Please set [Time & date] on the [Basic] screen of "Setup" before using the camera.
 - It is impossible to display H.265 (or H.264) or MJPEG images, receive/transmit audio, display logs, and use full-screen display when the viewer software "Network Camera View 4S" is not installed on the PC.
 - Depending on the environment of your PC, it may take time for images to be displayed.
 - At the time of purchase, the audio input and output connectors are set to "Off". If needed, change the setting on the "Audio" screen in "Setup".
 - Due to security enhancements in "IP Setting Software", "Network settings" cannot be changed when around 20 minutes have passed after turning on the power of the camera to be configured. (When the effective period is set to "20 min" in the "Easy IP Setup accommodate period".) However, settings can be changed after 20 minutes for cameras in the initial set mode.
 - Defocus may be caused by the reinstalled front cover. In this case, perform the auto focus function from the setup menu.
- If images are not displayed, set the Web browser to compatibility view. For details on how to configure, refer to our website (<https://security.panasonic.com/support/info/>) <Control No.: C0104>