

Panasonic

The EVA 1 Book



EVA
2.0
FIRMWARE

This document describes features available since
Firmware Version **2.02**



Table of contents

1. Sensor & format	5
1-1. Super 35mm sized imager with 5.7K resolution.....	6
1-2. Active area.....	6
1-3. Record time.....	7
1-4. Applicable memory cards.....	8
2. Preparation before filming	9
2-1. Terminals.....	10
2-2. Accessory and tripod mounting holes.....	11
2-3. HOME screen.....	12
2-3-1. COLOR settings.....	13
2-3-2. EI setting.....	14
2-3-3. AUDIO setting.....	15
2-3-4. INFO screen.....	19
2-4. User assignable buttons.....	22
2-4-1. Assigning features.....	23
2-4-2. Assignable functions.....	24
2-4-3. Checking functions assigned to USER buttons.....	25
3. MENU settings	26
3-1. MENU items over view.....	27
3-1-1. SYSTEM MODE.....	28
3-1-2. COLOR SETTINGS.....	28
3-1-3. USER SWITCHES.....	29
3-1-4. SIDE LOCK.....	29
3-1-5. LED & FAN.....	30
3-1-6. LCD.....	30
3-1-7. CLOCK.....	30
3-1-8. INFORMATION.....	30
3-1-9. LANGUAGE.....	31
3-1-10. INITIALIZE.....	31
3-1-11. FPS.....	32
3-1-12. SHUTTER.....	32
3-1-13. EI.....	33
3-1-14. WHITE.....	34
3-1-15. NR.....	34
3-1-16. LENS SETTING.....	34
3-1-17. IR SHOOTING.....	34
3-1-18. E.I.S.....	35
3-1-19. AUTO BLACK BALANCE.....	35
3-1-20. NAME EDIT.....	36
3-1-21. SCENE DATA.....	36
3-1-22. BLACK.....	36
3-1-23. GAMMA.....	37
3-1-24. KNEE.....	38
3-1-25. HLG KNEE.....	39
3-1-26. WHITE CLIP.....	39
3-1-27. DETAIL.....	39
3-1-28. SKIN DETAIL.....	39
3-1-29. CHROMA.....	40
3-1-30. MATRIX.....	40
3-1-31. COLOR CORRECTION.....	41

3-1-32. CARDS/MEDIA	42
3-1-33. CLIP NAME	42
3-1-34. 2 SLOTS FUNC.	42
3-1-35. PRE REC	42
3-1-36. REC FUNCTION	42
3-1-37. TC	43
3-1-38. AUDIO CH SETTINGS	44
3-1-39. AUDIO INPUT	44
3-1-40. AUDIO OUTPUT	45
3-1-41. REC BEEP SOUND	45
3-1-42. ALARM	45
3-1-43. SDI OUT	46
3-1-44. HDMI OUT	47
3-1-45. SDI/HDMI INDICATOR	48
3-1-46. SDI/HDMI MARKER	48
3-1-47. LCD INDICATOR	49
3-1-48. LCD MARKER	51
3-1-49. LCD FOCUS ASSIST	51
3-1-50. LCD EI ASSIST	52
3-1-51. LCD LEVELGAUGE	53
3-1-52. COLOR BARS	53
3-1-53. SCENE FILE	54
3-1-54. SETUP FILE	54
3-1-55. NETWORK SEL	55
3-1-56. NETWORK FUNC	55
3-1-57. NETWORK PROPERTY	55
3-1-58. CONNECTION HISTORY	56
3-1-59. NETWORK TOOLS	56
3-1-60. AREA SETTINGS	57

4. Understanding advanced features.....58

4-1. Understanding Variable Frame Rate (VFR) recording	59
4-2. Monitoring image and recording	60
4-3. Understanding focus assist modes	61
4-4. Understanding sport meter as Exposure Index (EI) assist	63
4-5. Understanding Electric Image Stabilizer (EIS) function	65
4-6. Understanding dual memory card slot feature	66
4-7. Synchronize timecode.....	67
4-8. Understanding remote operation via EVA ROP application.....	68
4-9. Understanding RAW output feature.....	71
4-10. Updating firmware.....	72

5. File format.....73

5-1. Folder structure in the record media	74
5-2. Folder name (MOV format)	75
5-3. File name (MOV format)	76

6. Appendix	77
6-1. Battery runtime	78
6-2. Scene file preset.....	79
6-3. Output signals (SDI&HDMI)	80
6-4. Error and warning system	84
6-5 Genuine accessories	88
6-6. Specifications	90
6-7. Dimensions.....	94
Revision history	95

1. Sensor & format

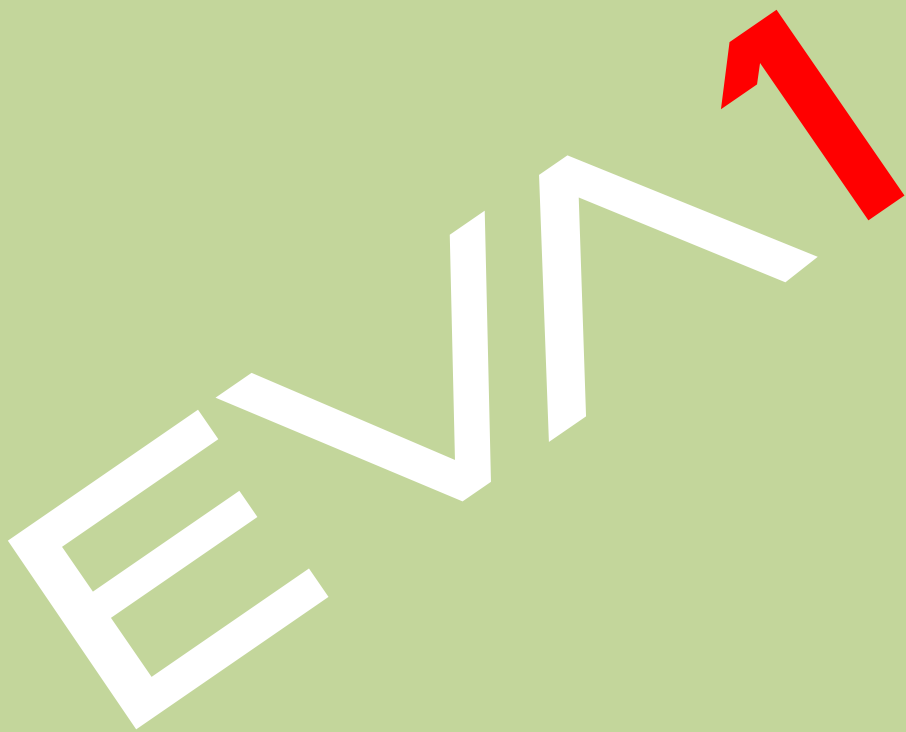

1. Sensor & format

The AU-EVA1 is a cinema camera recorder, featuring a newly developed super 35mm sized imager with 5.7K resolution, and can record in several formats and compression, offering up to 10-bit 4:2:2 even in 4K. The EVA1 contains V-Log/V-Gamut capture to deliver high dynamic range and a broad color gamut.

1-1. Super 35mm sized imager with 5.7K resolution

The new 17:9 imager (5720 x 3016 active pixels) achieves 2000 horizontal TV lines.

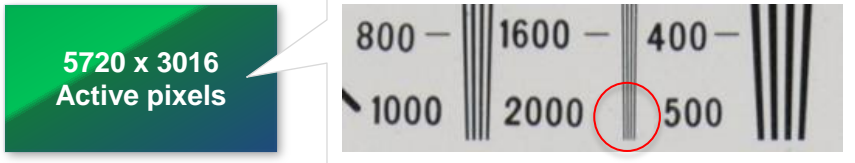

1-2. Active area

The EVA1 uses two different areas on its imager for capturing, depending on frame rate in variable frame rate (VFR) record mode. The areas, called S35 and 4/3 areas can be changed with the SENSOR MODE menu item.

MENU > SYSTEM SETTINGS > SENSOR MODE

-  S35 area (used for up to 120fps per second)
-  4/3 area (used for up to 240fps per second)

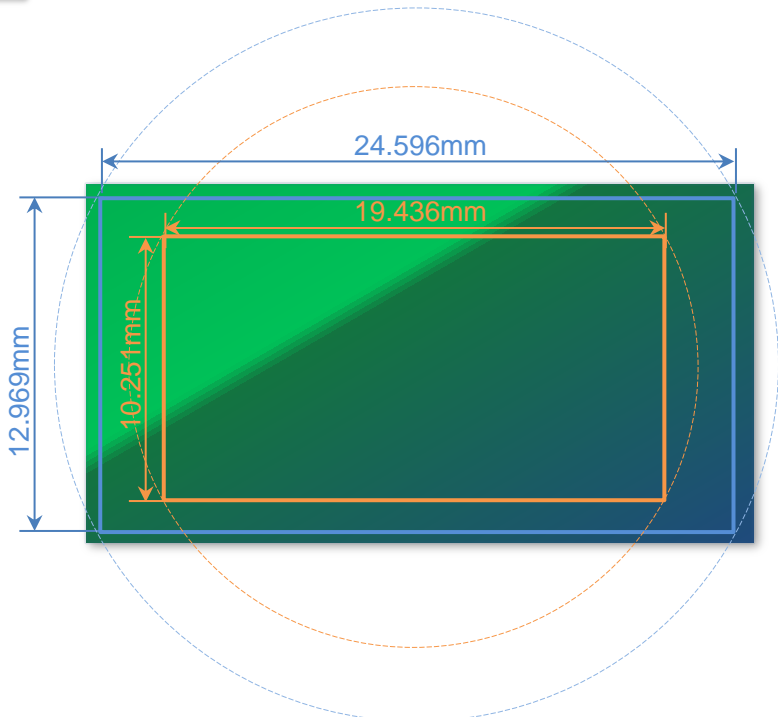

1. Sensor & format

1-3. Record time

(**Bold**: Available since firmware ver.2.02)



For mat	Resolution	Main Codec	Frame rate	Sampling	Rec time (128GB)
MOV	4096x2160 (4K)	422All-Intra 400M	29.97p, 24p, 25p, 23.98p	4:2:2 10bit	40m
		422LongGOP150M	29.97p, 24p, 25p, 23.98p	4:2:2 10bit	1h50m
		420LongGOP150M	59.94p, 50p	4:2:0 8bit	1h50m
		420LongGOP100M	29.97p, 24p, 25p, 23.98p	4:2:0 8bit	2h40m
	3840x2160 (UHD)	422All-Intra 400M	29.97p, 25p, 23.98p	4:2:2 10bit	40m
		422LongGOP150M	29.97p, 25p, 23.98p	4:2:2 10bit	1h50m
		420LongGOP150M	59.94p, 50p	4:2:0 8bit	1h50m
		420LongGOP100M	29.97p, 25p, 23.98p	4:2:0 8bit	2h40m
	2048x1080 (2K)	422All-Intra 200M	59.94p, 50p	4:2:2 10bit	1h20m
		422All-Intra 100M	29.97p, 24p, 25p, 23.98p	4:2:2 10bit	2h40m
		422LongGOP100M	59.94p, 50p	4:2:2 10bit	2h40m
		422LongGOP50M	29.97p, 24p, 25p, 23.98p	4:2:2 10bit	5h20m
		420LongGOP100M	59.94p, 50p	4:2:0 8bit	2h40m
		420LongGOP50M	29.97p, 24p, 25p, 23.98p	4:2:0 8bit	5h20m
	1920x1080 (FHD)	422All-Intra 200M	59.94p, 50p	4:2:2 10bit	1h20m
		422All-Intra 100M	29.97p, 25p, 23.98p, 59.94i, 50i	4:2:2 10bit	2h40m
		422LongGOP100M	59.94p, 50p	4:2:2 10bit	2h40m
		422LongGOP50M	29.97p, 25p, 23.98p, 59.94i, 50i	4:2:2 10bit	5h20m
420LongGOP100M		59.94p, 50p	4:2:0 8bit	2h40m	
420LongGOP50M		29.97p, 25p, 23.98p	4:2:0 8bit	5h20m	
AVCHD	1920x1080 (FHD)	PS (Ave.25Mbps)	59.94p, 50p	4:2:0 8bit	11h
		PH (Ave.21Mbps)	23.98p, 59.94i, 50i	4:2:0 8bit	12h30m
		HA (Ave.17Mbps)	59.94i, 50i	4:2:0 8bit	17h
	1280x720 (HD)	PM (Ave.8Mbps)	59.94p, 50p	4:2:0 8bit	35h

Record times are approx.

1. Sensor & format

1-4. Applicable memory cards

Applicable type or speed class of SD memory card varies depends on record format and mode.

Format	SD memory card type	Record bit-rate, record mode	Minimum requirement of speed class		
			Speed class	UHS speed class	Video speed class
MOV		400Mbps	--	--	V60
		2K/FHD, VFR mode (Intra codec)			
		200Mbps	--	U3	V30
		150Mbps			
		100Mbps			
		2K/FHD, VFR mode (Long-GOP codec)			
50Mbps	10	U1	V10		
AVCHD		PS, PH, HA, PM	4	--	--

NOTE:

When an SD memory card is mounted into the unit, the EVA1 detects its manufacturer's rated write speed, and displays an **"INCOMPATIBLE CARD"** message if that write speed is not fast enough for the chosen recording format. See Figure1 below. Recording is still available even with this warning message but a sudden stop of the recording or other events may occur. To avoid issue, use only SD memory cards that meet the required consistent write speeds as noted on the chart above.



Fig.1 Message displayed when mounting an SD card of a lower video speed class than required for the codec selected on the camera.

2. Preparation before filming



2. Preparation before filming

2-1. Terminals

Image resolution of HDMI and SDI OUT signals vary depend on the system settings.

See 6-3. Output signals (SDI&HDMI) (6-3. Output signals (SDI)P.80-エラー! ブックマークが定義されていません。)

REAR VIEW



2. Preparation before filming

2-2. Accessory and tripod mounting holes

The AU-EVA1 has multiple standard screw holes for accessories, industrial standard **1/4-20UNC** size and cinema/broadcast equipment standard **3/8-16UNC**. Two holes are prepared on the carrying handle and eight holes on the top. Use screws shorter than 5.5mm in length, otherwise damage may occur to internal parts.

TOP VIEW



BOTTOM VIEW

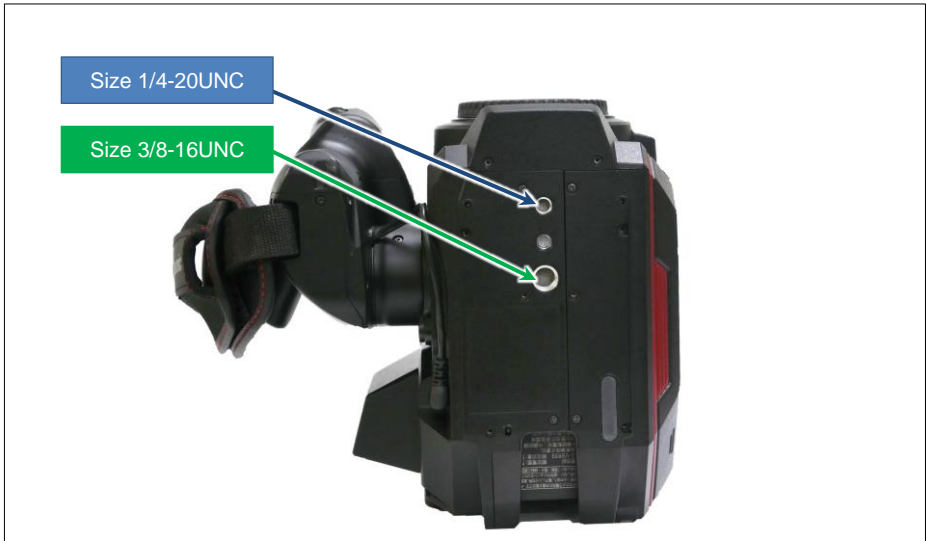

2. Preparation before filming

2-3. HOME screen

Centralized control screen can be recalled by pressing the HOME button. Various functions can be rapidly accessed from this screen.

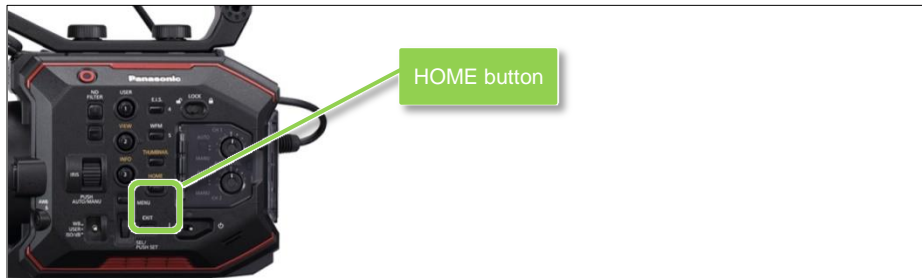

COLOR (Gamma & Gamut)
See P.13 for details.

Switching ON/OFF VFR, and frame rate, rates to be listed can be added/removed at MENU > CAMERA SETTINGS > FPS > ADD/DELETE (max.128)

Switching ON/OFF shutter, and angle/speed, display mode (deg./sec.) can be switched at MENU > CAMERA SETTINGS > SHUTTER > MODE

23.98 fps	V-Log	180.0 deg
FPS	COLOR	SHUTTER
4096x2160 / 23.98p 422LongG 150M	P 1 56min 2 49min RELAY	Wi-Fi A007 C001
TCG 09:44:57:01	CH1 [meter] CH2 [meter]	SDI HDMI LCD V-Log V-Log V-Log
EI	AUDIO	WB
NATIVE ISO 800	CH1 INT(L) CH2 INT(R)	3200 K

EI (Exposure Index), display mode (ISO/dB) can be switched at MENU > EI > MODE

Audio settings,
See P.14 for details.

White balance preset, Values registered in advance can be recalled. Add/remove its value at MENU > CAMERA SETTINGS > WB > ADD/DELETE (max.12)

2. Preparation before filming

2-3-1. COLOR settings



On the AU-EVA1, settings of Gamma & Gamut is called "COLOR". Image COLOR to be recorded can be set in the MAIN COLOR screen. COLOR settings for SDI, HDMI, and LCD output can individually be set.

Selectable from V-Log, SCENE1, SCENE2, SCENE3, SCENE4, SCENE5. For more details about SCENE settings, see 6-2. Scene file preset (P.79).

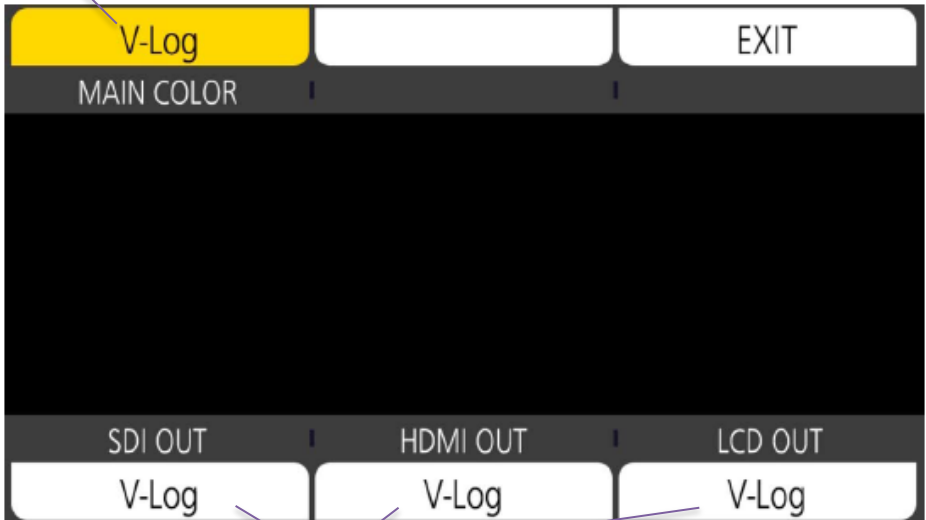

Selectable form V-Log or V-709 when MAIN COLOR is set to V-Log.

2. Preparation before filming

2-3-2. EI setting

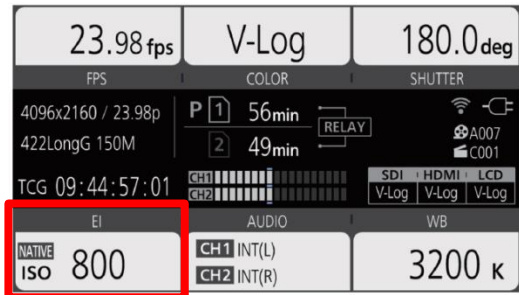

Setting of Exposure Index (ISO)

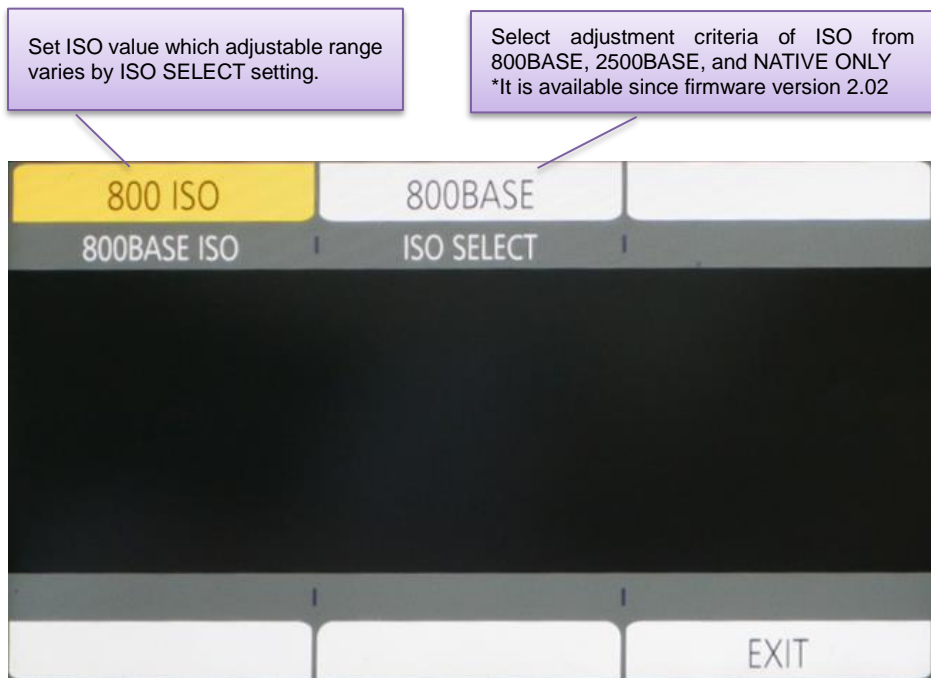

2. Preparation before filming

2-3-3. AUDIO setting



Assignment of audio channel and setting of audio source.

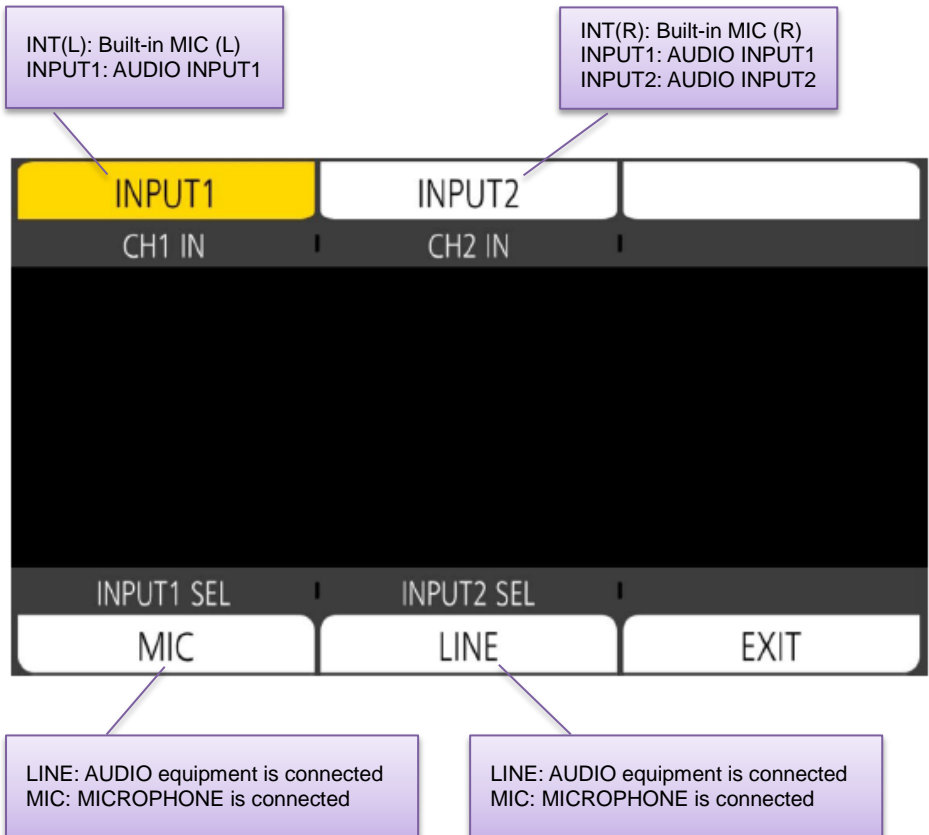

2. Preparation before filming

2-3-3. Audio setting (continued)

The AU-EVA1 is equipped with a built-in stereo microphone and two external audio inputs. Different levels (LINE/MIC) can be assigned for external inputs.

Setting audio (record with the built-in microphone)

1. In HOME screen, tap “AUDIO” item.



2. Set CH1 IN to INT(L) and CH2 IN to INT(R) respectively for audio source.

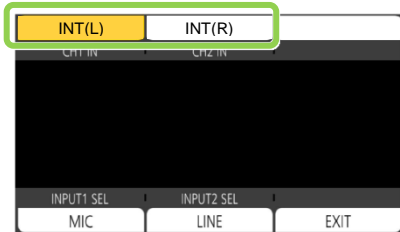

3. Set audio record level knob. To use automatic level adjustment, set the AUTO/MANU switch to “AUTO”.



Audio record level controls

2. Preparation before filming

2-3-3. Audio setting (continued)

Setting audio (record with the external microphone)

1. Switch OFF the power of the EVA1 and connect microphone(s) to AUDIO INPUT terminals.



2. Switch ON the power of the EVA1 and tap “AUDIO” item at the HOME screen, and then set CH1 IN to INPUT1 and CH2 IN to INPUT2 for audio source.

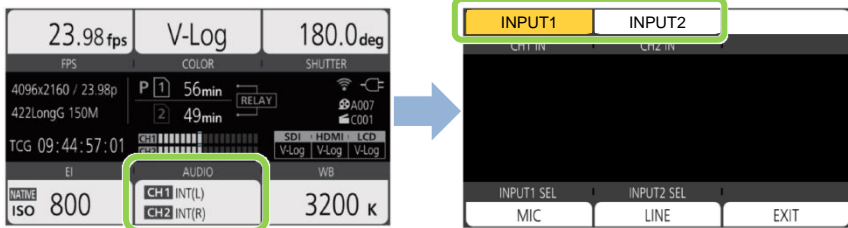

3. Set INPUT1 SEL to MIC and INPUT2 SEL to MIC for audio level.

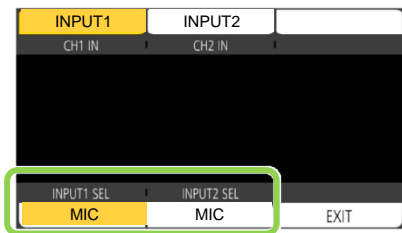

4. Set following items in MENU > AUDIO SETTINGS > AUDIO INPUT screen.

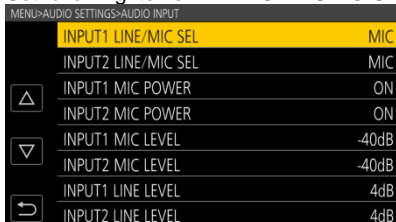

Set to “ON” when the microphone requires +48V power supply from the EVA1.

Choose the closest sensitivity with the microphone.

2. Preparation before filming

- Set audio record level knob. To use automatic level adjustment, set the AUTO/MANU switch to "AUTO".



Audio record level controls

NOTE: How to set INPUT MIC LEVEL

MIC level can be set to -40dB, -50dB or -60dB as determined by MENU > AUDIO INPUT > INPUT MIC LEVEL. Choose the closest value with sensitivity your microphone has. Following is an example of one of Panasonic's microphone AG-MC200G. With this microphone, choosing "-40dB" would be suitable as the closest value with the microphone.

Specifications

Power supply: Phantom power supply, 48 V DC
Current consumption: 2.0 mA (typical)

☐ indicates safety information.

Type:

Back electret capacitor type microphone

Frequency response:

160 Hz to 20 kHz

Sensitivity:

-40 dB \pm 3.5 dB () dB = 1 V/Pa, at 1 kHz

maximum input sound pressure level:

127 dB S.P.L. (at 1 kHz, 1% distortion)

S/N ratio (1 kHz/Pa):

69 dB or more

Output Impedance:

100 Ω \pm 30% (at 1 kHz)

Output connector:

XLR (3 pins)

Sensitivity specification example of a microphone (Panasonic AG-MC200G)

2. Preparation before filming

2-3-4. INFO screen

This screen can be displayed by pressing INFO button in HOME screen mode.

DIAGNOSTIC: See 6-4. Error and warning system (P.84) for details of error and warning messages.



SWITCHES: Displays functions assigned to USER buttons at a glance.

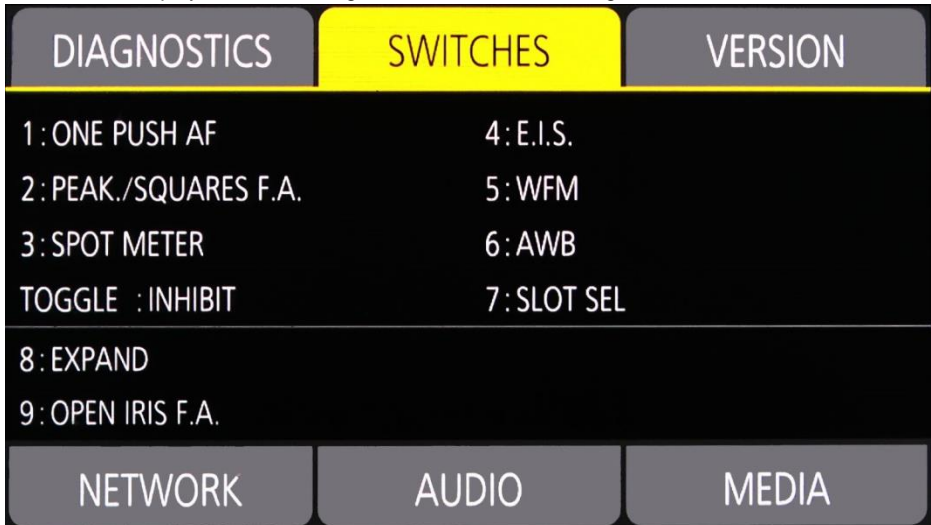

2. Preparation before filming

2-3-4. INFO screen (continued)

VERSION: Displays firmware version of the unit.



NETWORK: Displays network related settings.



2. Preparation before filming

2-3-4. INFO screen (continued)

AUDIO: Displays audio related settings.

DIAGNOSTICS SWITCHES VERSION

CH1 SELECT : INT(L)
CH2 SELECT : INT(R)
CH1 LEVEL : MANUAL LIMITER:OFF
CH2 LEVEL : MANUAL LIMITER:OFF
HEAD ROOM : 20dB
MONITOR : STEREO DELAY:LIVE VOL:70

NETWORK AUDIO MEDIA

MEDIA: Displays memory card status.

DIAGNOSTICS SWITCHES VERSION

SLOT REMAIN/ALL
1 : NO CARD
2 : NO CARD

NETWORK AUDIO MEDIA

2. Preparation before filming

2-4. User assignable buttons

Features can quickly be recalled from 9 user assignable buttons and a dial.

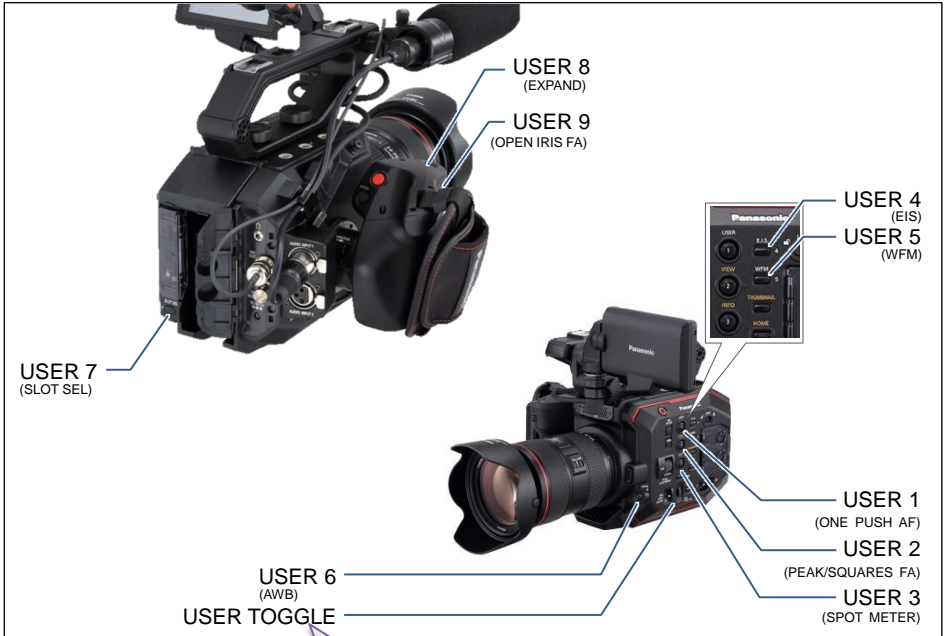

1. Choose one of the features (shutter, frame rate, audio monitor volume)

```
MONI-SYSTEM SETTINGS-USER SWITCHES
```

USER3	SPOT METER
USER4	E.I.S.
USER5	WFM
USER6	AWB
USER7	SLOT SEL
USER8	EXPAND
USER9	OPEN IRIS F.A.
USER TOGGLE	MONITOR VOL

2. Set the toggle SW to "USER"

3. Operate assigned feature directly

```
MONI-SYSTEM SETTINGS-USER SWITCHES-USER TOGGLE
```

INHIBIT
SHUTTER
FPS
✓ MONITOR VOL

2. Preparation before filming

2-4-1. Assigning features

MENU > SYSTEM SETTINGS > USER SWITCHES > Assign any function to any button.

The image shows three screenshots of a camera's menu system. The first screenshot shows the 'MENU' screen with 'SYSTEM SETTINGS' highlighted. A red arrow points to the second screenshot, which shows 'MENU>SYSTEM SETTINGS' with 'USER SWITCHES' highlighted. A second red arrow points to the third screenshot, which shows 'MENU>SYSTEM SETTINGS>USER SWITCHES' with a list of assignable functions. The functions are listed in a table with 'USER' names on the left and function names on the right. 'USER1' is assigned to 'COLOR BARS', 'USER2' to 'PEAK./SQUARES F.A.', 'USER3' to 'SPOT METER', 'USER4' to 'E.I.S.', 'USER5' to 'WFM', 'USER6' to 'AWB', 'USER7' to 'SLOT SEL', 'USER8' to 'EXPAND', 'USER9' to 'OPEN IRIS F.A.', and 'USER TOGGLE' to 'MONITOR VOL'. Red boxes highlight the 'USER' names and the function names in the third screenshot.

USER	Function
USER1	COLOR BARS
USER2	PEAK./SQUARES F.A.
USER3	SPOT METER
USER4	E.I.S.
USER5	WFM
USER6	AWB
USER7	SLOT SEL
USER8	EXPAND
USER9	OPEN IRIS F.A.
USER TOGGLE	MONITOR VOL

* See P.24 for assignable functions including their details.

2. Preparation before filming

2-4-2. Assignable functions

(Ⓞ) : Feature that turns OFF when switch off the unit once.

Menu item	Description
INHIBIT	The USER button is disabled (nothing is assigned).
AWB	Perform the auto white balance adjustment.
ONE PUSH AF	Focus mode becomes AUTO while keep pressing the USER button. This function works with lenses equipped with AF function.
ONE PUSH A.IRIS	Iris mode becomes AUTO while keep pressing the USER button.
(Ⓞ) ATW LOCK	Maintain and lock the last white balance achieved by ATW mode.
E.I.S.	Turn ON/OFF the electric image stabilizer.
(Ⓞ) D.ZOOM	Use 1.4x digital zoom (electric image magnification) feature.
IR SHOOTING	Turn ON/OFF the Infrared shooting feature.
REC SW	Perform record start/stop.
PRE REC	Turn ON/OFF the pre-record mode. This mode allows the camera to start recording video and audio approx. 10 seconds (when MAIN PIXEL setting is set to 1280x720, 1920x1080, or 2048x1080), approx. 5 seconds for the others.
REC CHECK	Plays last 2 seconds of the latest recorded clip on the SD memory card.
DEL LAST CLIP	Delete the last clip from the SD memory card.
SLOT SEL	Switch SD memory card slots for recording/playing back.
(Ⓞ) EXPAND	Turn ON/OFF image magnification focus assist function.
OPEN IRIS FA	Turn ON/OFF a focus assist function that makes focusing easier by opening aperture (i.e. by making depth of field shallower).
(Ⓞ)PEAK/SQUARES FA	Turn ON/OFF peaking and square focus assist function. Focus mode (peaking or square) can be set: MENU > OUTPUT SETTINGS > LCD FOCUS ASSIST > PEAK/SQUARES MODE
(Ⓞ) WFM	Display the waveform or vector scope on the LCD monitor. Display type can be set in MENU > OUTPUT SETTINGS > LCD EI ASSIST > WFM MODE
(Ⓞ) SPOT METER	Turn ON/OFF the spot meter function. It is available when following menu setting is set to "SPOT METER". MENU > OUTPUT SETTINGS > SDI/HDMI INDICATOR or LCD INDICATOR
ZEBRA	Turn ON/OFF the ZEBRA indicator.
LEVEL GAUGE	Display a level gauge on the LCD monitor for the horizontal and vertical axis. Indications can be indicated up to approx.30 degrees in the horizontal directions and, and up to approx. 30 degrees in the vertical.
LEVEL GAUGE SET	Set the current horizontal and vertical position as the reference point for the level gauge.
SDI COLOR	Switch image color (SDI OUT).
HDMI COLOR	Switch image color (HDMI OUT)
LCD COLOR	Switch image color (LCD OUT)
(Ⓞ) LCD CLEAN VIEW	Show/hide characters on/from the LCD OUT image.
LCD MARKER	Show/hide a marker on/from the LCD OUT image.
(Ⓞ) COLOR BARS	Turn ON/OFF the color bars display.
(Ⓞ) POWER LCD	Boost up brightness of LCD panel for outdoor use.

2. Preparation before filming

2-4-3. Checking functions assigned to USER buttons

Press "HOME" button > "INFO" button > tap "SWITCHES"



HOME button

INFO button

HOME screen

23.98 fps	V-Log	180.0 deg
FPS	COLOR	SHUTTER
4096x2160 / 23.98p	P 1 56min	RELAY
422LongG 150M	2 49min	A007 C001
TCG 09:44:57:01	SDI HDMI LCD	V-Log V-Log V-Log
EI	AUDIO	WB
NATIVE ISO 800	CH1 INT(L) CH2 INT(R)	3200 K



Press "INFO" button

DIAGNOSTICS	SWITCHES	VERSION
1: ONE PUSH AF	4: E.I.S.	
2: PEAK./SQUARES F.A.	5: WFM	
3: SPOT METER	6: AWB	
TOGGLE : INHIBIT	7: SLOT SEL	
8: EXPAND		
9: OPEN IRIS F.A.		
NETWORK	AUDIO	MEDIA

3. MENU settings



3. MENU settings

3-1. MENU items over view

The AU-EVA1 has two levels of menu layers.

MENU	Purpose	How to open
MENU	Most of basic and advanced settings can be set in this layer.	Press “MENU” button or keep pressing LCD touch screen for 1 second while VIEW screen is displayed.
OPTION MENU	Some initial settings.	Press “MENU” button while keep pressing “EXIT” button.

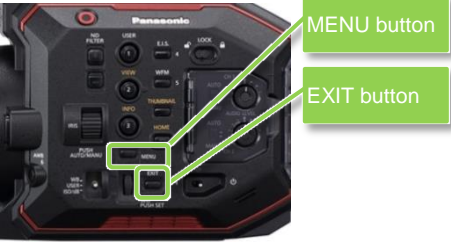

MENU (Press “MENU” button)

- SYSTEM SETTINGS (Fundamental settings such as CODEC etc.) [P.28]
- CAMERA SETTINGS (Sensitivity, shutter etc.) [P.32]
- SCENE FILE SETTINGS (Image related settings) [P.36]
- REC SETTINGS (Recording related such as Pre-REC, TC set) [P.42]
- AUDIO SETTINGS (Input gain and other audio related settings) [P.44]
- OUTPUT SETTINGS (HDMI, SDI, LCD output related settings) [P.46]
- FILE (Loading/saving scene files, setting files) [P.54]
- NETWORK SETTINGS (Wi-Fi related settings) [P.55]

OPTION MENU (Press “EXIT” + “MENU” button)

- AREA SETTINGS (Region related settings) [P.57]
(NOT available for some models.)

3. MENU settings (SYSTEM SETTINGS)

3-1-1. SYSTEM MODE

Menu item	Description	Value (factory default setting underlined)
FREQUENCY	Set the system frequency	<u>23.98p</u> , 24.00p, 25.00p, 29.97p, 50.00p, 59.94p, 50.00i, 59.94i
SDI RAW	Set resolution for RAW data out. See 4-9. Understanding RAW OUT (P.71) for the details.	<u>OFF</u> , S35 5.7K, CROP 4K, CROP&MIX 2K
SENSOR MODE	Set the sensor drive mode See 4-1. Understanding Variable Frame Rate (VFR) recording (P.59) for the details.	<u>S35 5.7K</u> , S35 MIX2.8K, 4/3 CROP&MIX 2.2K
MAIN PIXEL	Set resolution for main recorder.	<u>4096x2160</u> , 3840x2160, 2048x1080, 1920x1080, 1280x720
MAIN CODEC	Set the main record codec	MOV 420LongGOP150M, 420LongGOP100M, 420LongGOP50M, <u>422LongGOP150M</u> , 422LongGOP100M, 422LongGOP50M AVCHD AVCHD PS, AVCHD PH, AVCHD HA, AVCHD PM

* SENSOR MODE, MAIN PIXEL, and MAIN CODEC settings cannot be changed when SDI RAW item is in use.

3-1-2. COLOR SETTINGS

Menu item	Description	Value (factory default setting underlined)
MAIN	Set the COLOR to be recorded as the system color.	<u>V-Log</u> , SCENE1, SCENE2, SCENE3, SCENE4, SCENE5
SDI OUT	Set the COLOR of image to be output from SDI OUT.	When MAIN item is set to "V-Log" V-Log, V-709 When MAIN item is set to "SCENE **" The SCENE* is applied.
HDMI OUT	Set the COLOR of image to be output from HDMI OUT.	When MAIN item is set to "V-Log" V-Log, V-709 When MAIN item is set to "SCENE **" The SCENE* is applied.
LCD OUT	Set the COLOR of image to be output from LCD OUT.	When MAIN item is set to "V-Log" V-Log, V-709 When MAIN item is set to "SCENE **" The SCENE* is applied.

About V-Log and V-709

V-Log	V-Log is an image capture log curve that achieves wider latitude (+14 stops) and fine scene gradations.
V-709	V-709 is a gamma curve, whose characteristic allows direct pre-viewing of camera images on a TV monitor.

3. MENU settings (SYSTEM SETTINGS)

3-1-3. USER SWITCHES

Menu item	Description	Value (factory default setting underlined)
USER 1	ONE PUSH AF	Features can be assigned to 9 user buttons and a dial. See 2-4. User assignable buttons (P.22) for the details.
USER 2	PEAK/SQUARES F.A.	
USER 3	SPOT METER	
USER 4	E.I.S.	
USER 5	WFM	
USER 6	AWB	
USER 7	SLOT SEL	
USER 8	EXPAND	
USER 9	OPEN IRIS F.A.	
USER TOGGLE	MONITOR VOL	

3-1-4. SIDE LOCK

Menu item	Description	Value (factory default setting underlined)
REC	LOCK , <u>UNLOCK</u>	The AU-EVA1 has a key lock switch, Keys and a Dial to be locked or not can be selected.
USER 1	<u>LOCK</u> , UNLOCK	
USER 2	<u>LOCK</u> , UNLOCK	
USER 3	<u>LOCK</u> , UNLOCK	
USER 4	<u>LOCK</u> , UNLOCK	
USER 5	<u>LOCK</u> , UNLOCK	
USER 6	<u>LOCK</u> , UNLOCK	
USER 7	<u>LOCK</u> , UNLOCK	
THUMBNAIL	<u>LOCK</u> , UNLOCK	
HOME	<u>LOCK</u> , UNLOCK	
ND FILTER	<u>LOCK</u> , UNLOCK	
IRIS DIAL	<u>LOCK</u> , UNLOCK	
MENU	<u>LOCK</u> , UNLOCK	
EXIT	<u>LOCK</u> , UNLOCK	
MULTI DIAL	<u>LOCK</u> , UNLOCK	



LOCK switch located at left side of the unit

3. MENU settings (SYSTEM SETTINGS)

3-1-5. LED & FAN

Menu item	Description	Value (factory default setting underlined)
TALLY LED	Set the tally lamp to be used during recording.	FRONT, REAR, <u>BOTH</u> , OFF
ACCESS LED	Set the access lamp to be used when accessing memory card.	<u>ON</u> , OFF
POWER LED	Set the power indicator to be used.	<u>ON</u> , OFF
FAN SPEED	Set rotation mode of the cooling fan.	<u>AUTO</u> : Adjust rotation speed in response to inside temperature of the unit. FULL: Rotate at a constant speed

3-1-6. LCD

Menu item	Description	Value (factory default setting underlined)
BRIGHTNESS	Adjust the brightness of the LCD monitor.	-15 -- <u>0</u> -- 15
COLOR LEVEL	Adjust the saturation level of the LCD monitor.	-15 -- <u>0</u> -- 15
CONTRAST	Adjust the contrast level of the LCD monitor.	-30 -- <u>0</u> -- 30
BACK LIGHT	Adjust brightness of the backlight of the LCD monitor.	-1 , <u>0</u> , 1

3-1-7. CLOCK

Menu item	Description	Value (factory default setting underlined)
CLOCK SETTING	Set the built-in calendar.	---
TIME ZONE	Set time difference to the calendar information.	-12:00 -- +13:00
DATE FORMAT	Set date format.	Y-M-D , M-D-Y , D-M-Y

3-1-8. INFORMATION

Menu item	Description	Value (factory default setting underlined)
VERSION	MODEL	Display product model number
	SERIAL NO.	Display serial number
	VERSION	Display firmware version
OPERATION TIME	TOTAL OPERATION	Display accumulated power on time in hours.
	IRIS DIAL	Display accumulated operation (turn) times of IRIS dial in x100 times.
SENSOR TEMP	Display ambient temperature of the image sensor in C degree.	Example 000037 = 37°C
USB SERVICE MODE	For service purpose	---
UPDATE	For firmware update operation	---

3. MENU settings (SYSTEM SETTINGS)

3-1-9. LANGUAGE

Menu item	Description	Value (factory default setting underlined)
LANGUAGE	Set the menu language	---

* This menu item will not be displayed for some models and when the AREA SETTING item in the OPTION MENU (see P.57) is set to "AREA1".

3-1-10. INITIALIZE

Menu item	Description	Value (factory default setting underlined)
LOAD FACTORY DATA	Restore the product to factory settings.	YES , NO

3. MENU settings (CAMERA SETTINGS)

3-1-11. FPS

Menu item	Description	Value (factory default setting underlined)
VFR SW	Turn ON/OFF variable frame rate mode.	ON , <u>OFF</u>
VALUE	Set frame rate.	The maximum number of frame rate (FPS) can vary depends on setting "SYSTEM SETTING > SENSOR MODE". <u>SENSOR MODE and maximum FPS</u> S35 5.7K : max. 60fps S35 MIX 2.8K : max. 120fps 4/3 CROP&MIX 2.2K : max. 240fps See 4-1. Understanding Variable Frame Rate (VFR) recording (P.59) for details of SENSOR MODE settings
ADD	Set frame rates to be selected.	(maximum 150 values)
EDIT	Edit information of selectable frame rates	---
DELETE	Remove FPS value from the select list.	---

3-1-12. SHUTTER

Menu item	Description	Value (factory default setting underlined)	
SW	Turn ON/OFF the electric shutter.	<u>ON</u> , OFF	
MODE	Switch display unit of the shutter.	Sec (speed) , deg (open angle)	
deg	VALUE deg	Recall open angle of shutter on a preset table. <u>HALF SHUTTER</u> , 11.5d, 22.5d, 45.0d, 90.0d, 120.0d, 144.0d, 172.8d, 180.0d, 270.0d, 357.0d	
	ADD deg	Add an open angle to the preset table. (max.12)	---
	EDIT deg	Edit the shutter preset table.	---
	DELETE deg	Delete an open angle from the preset table.	---
sec	VALUE sec	Recall a speed on a preset table. <u>HALF SHUTTER</u> , 1/60.0, 1/100.0, 1/120.0, 1/250, 1/500, 1/1000, 1/2000	
	ADD sec	Add a speed to the preset table. (max.12)	---
	EDIT sec	Edit the shutter preset table.	---
	DELETE sec	Delete a speed from the preset table.	---

3. MENU settings (CAMERA SETTINGS)

3-1-13. EI

Menu item	Description	Value (factory default setting underlined)
MODE	Set unit of Exposure Index (EI)	<u>ISO</u> , dB
ISO SELECT	Set the EI control mode when ISO is selected in the MODE item.	<u>NATIVE ONLY</u> , 800BASE, 2500BASE
NATIVE ISO	Select the value of ISO value when NATIVE ONLY is selected.	When GAMMA SELECT is set to "VIDEO" 400 ISO, 1250 ISO When other value is chosen for GAMMA SELECT <u>800 ISO</u> , 2500 ISO
800BASE ISO	Select the value of ISO value when 800 BASE is selected.	When GAMMA SELECT is set to "VIDEO" 200, 250, 320, 400, 500, 640, 800, 1000ISO When other value is chosen for GAMMA SELECT 200, 250, 320, 400, 500, 640, <u>800</u> , 1000, 1250, 1600, 2000 ISO
2500BASE ISO	Select the value of ISO value when 2500 BASE is selected.	When GAMMA SELECT is set to "VIDEO" 640, 800, 1000, 1250, 1600, 2000, 2500, 3200, 4000, 5000, 6400, 8000, 10000, 12800, 16000, 20000, 25600ISO When other value is chosen for GAMMA SELECT 1000, 1250, 1600, 2000, <u>2500</u> , 3200, 4000, 5000, 6400, 8000, 10000, 12800, 16000, 20000, 25600ISO
GAIN MODE	Set the EI control mode when dB is selected in the MODE item.	<u>NORMAL</u> , HIGH
GAIN SELECT	GAIN MODE = NORMAL	When GAMMA SELECT is set to "VIDEO" -6dB, -4dB, -2dB, 0dB, 2dB, 4dB, 6dB, 8dB When other value is chosen for GAMMA SELECT -12dB, -10dB, -8dB, -6dB, -4dB, -2dB, <u>0dB</u> , 2dB, 4dB, 6dB, 8dB
	GAIN MODE = HIGH	When GAMMA SELECT is set to "VIDEO" -6dB, -4dB, -2dB, 0dB, 2dB, 4dB, 6dB, 8dB, 10dB, 12dB, 14dB, 16dB, 18dB, 20dB, 22dB, 24dB, 26dB When other value is chosen for GAMMA SELECT -8dB, -6dB, -4dB, -2dB, 0dB, 2dB, 4dB, 6dB, 8dB, 10dB, 12dB, 14dB, 16dB, 18dB, 20dB

3. MENU settings (CAMERA SETTINGS)

3-1-14. WHITE

Menu item	Description	Value (factory default setting underlined)
AWB	Perform Auto white balance adjustment	Available when VALUE item is set to "AWB MEMORY" only.
VALUE	Recall auto white balance value on a preset table.	ATW, AWB MEMORY, <u>3200K+0.0GMg</u> , 4300K+0.0GMg, 5600K+0.0GMg, 6300K+0.0GMg
ADD	Add an AWB value to the preset table. (max.12)	---
EDIT	Edit the preset table.	---
DELETE	Delete a value from the preset table.	---

3-1-15. NR

Menu item	Description	Value (factory default setting underlined)
ISO800	Set amount of reduction in 800 BASE ISO mode.	2, 1, <u>OFF</u>
ISO2500	Set amount of reduction in 2500 BASE ISO mode.	2, 1, <u>OFF</u>

3-1-16. LENS SETTING

Menu item	Description	Value (factory default setting underlined)
A.IRIS LEVEL EFFECT	Set the target brightness level in auto iris mode.	0 -- <u>50</u> -- 100
A.IRIS WINDOW	Set the auto iris detection window.	<u>NORMAL1</u> : Window is set to center NORMAL2: Window is set to bottom side CENTER: Window is set to center (spot)
A.IRIS PEAK/AVE	Set a ratio of auto iris control (peak or average)	0 -- <u>30</u> -- 100 Auto iris response becomes sensitive when increase the value.
GRIP IRIS	Set control direction for the dial on the hand-grip part.	RIGHT OPEN: Iris opens when turn the dial outward. LEFT OPEN: Iris opens when turn the dial inward.
AF OFFSET	Adjust offset of focus position.	← Near -20 -- <u>0</u> -- 20 Far →

3-1-17. IR SHOOTING

Menu item	Description	Value (factory default setting underlined)
IR SHOOTING	Turn ON/OFF infrared shooting mode.	ON, <u>OFF</u>

3. MENU settings (CAMERA SETTINGS)

3-1-18. E.I.S.

Menu item	Description	Value (factory default setting underlined)
SW	Turn ON/OFF electric image stabilizer.	ON, <u>OFF</u>
ZOOM POSITION DATA	Set focal length of the lens for precise electric image stabilizing operation.	<u>AUTO</u> , MANUAL For AUTO adjustment, EF lenses that support providing focal length information is required.
ZOOM POSITION VALUE	Set focal length of the lens currently mounted. *Available when ZOOM POSITION DATA item is set to "MANUAL".	8 – 200

3-1-19. AUTO BLACK BALANCE

Menu item	Description	Value (factory default setting underlined)
ABB	Perform Auto Black Balance adjustment.	---

3. MENU settings (SCENE FILE SETTINGS)

3-1-20. NAME EDIT

Menu item	Description	Value (factory default setting underlined)
NAME EDIT	Edit scene file name	Max. eight characters

3-1-21. SCENE DATA

Menu item	Description	Value (factory default setting underlined)
LOAD	Load custom scene files from the built-in memory.	YES, NO
SAVE	Save custom scene files to the built-in memory.	YES, NO
INITIALIZE	Restore scene files to the factory settings.	YES, NO

3-1-22. BLACK

Menu item	Description	Value (factory default setting underlined)
M.PED	Set the master pedestal level (reference of black).	-100 -- 0 -- 100
R PED	Set the pedestal level for Red channel.	-100 -- 0 -- 100
G PED	Set the pedestal level for Green channel.	-100 -- 0 -- 100
B PED	Set the pedestal level for Blue channel.	-100 -- 0 -- 100
PEDESTAL OFFSET	Select behavior of pedestal level after ABB performed.	<u>ON</u> : Add pedestal offset of R PED, G PED, and B PED after ABB is performed. <u>OFF</u> : Clear all values of R PED, G PED, and B PED after ABB is performed.

3. MENU settings (SCENE FILE SETTINGS)

3-1-23. GAMMA

Menu item	Description	Value (factory default setting underlined>)
GAMMA SELECT	Set gamma mode	V-255570L1, V-504580L1, VIDEO, HLG

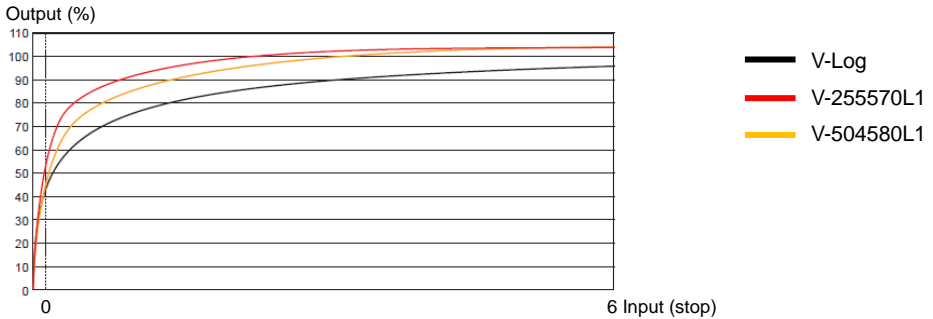

V-255570L1: Attaching importance to contrast

The curve has 14 stop of latitude. The V-255570 means that start curve angle up to 10% is approx. 2.5x, gamma value 0.55 up to 70%. Recommended face tone level range 40 to 50%.

V-504580L1: Attaching importance to softer image

The curve has 14 stop of latitude. The V-504580 means that start curve angle up to 10% is approx. 5.0x, gamma value 0.45 up to 80%. Recommended face tone level range 40 to 60%.

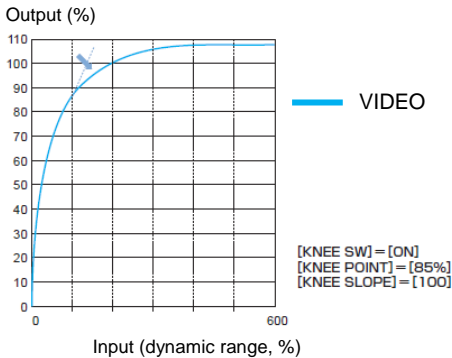

VIDEO: Broadcast look

It is designed to express conventional video camera's characteristic with 600% of dynamic range.

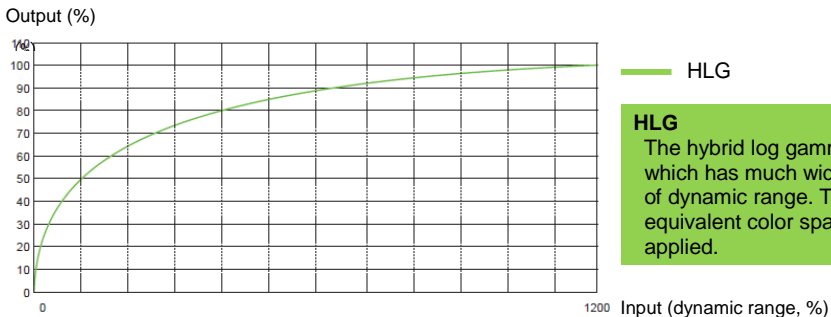

HLG

The hybrid log gamma curve, which has much wider 1200% of dynamic range. The BT.2020 equivalent color space is applied.

3. MENU settings (SCENE FILE SETTINGS)

GAMMA (continued)

Menu item	Description	Value (factory default setting underlined)
MASTER GAMMA	Set master gamma curve in units of 0.01.	0.30 -- 0.75
BLACK GAMMA	Set depression and expansion of gamma curve for dark areas.	(Depressing) -8 -- <u>OFF</u> -- +8 (Expanding)
B.GAMMA RANGE	Set the maximum level of compression/expansion.	1 : Approx. 20% 2 : Approx. 30% 3 : Approx. 40%

3-1-24. KNEE

Menu item	Description	Value (factory default setting underlined)
KNEE SW	Turn ON/OFF the KNEE.	<u>ON</u> , OFF
KNEE MODE	Set the KNEE mode.	<u>D RANGE</u> , PRESS
KNEE POINT	Set the KNEE point in units of 1%.	55% -- <u>85%</u> -- 100%
KNEE SLOPE	Set the KNEE slope.	0 – <u>100</u>

KNEE Effect

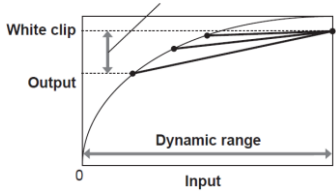
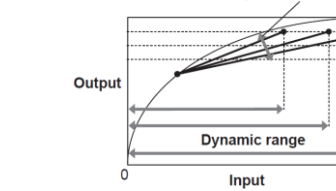
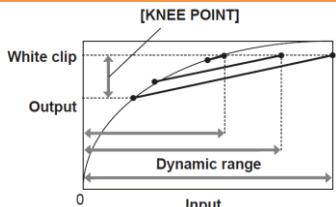
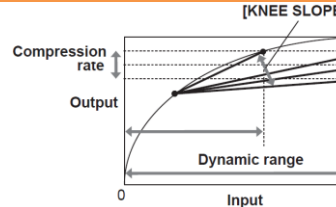
KNEE MODE	KNEE POINT [KNEE POINT]	KNEE SLOPE [KNEE SLOPE]
D RANGE	 <p>Does not affect dynamic range</p>	 <p>Dynamic range varies with KNEE SLOPE control</p>
PRESS	 <p>Dynamic range varies with KNEE POINT control</p>	 <p>Dynamic range and signal compression level vary</p>

3. MENU settings (SCENE FILE SETTINGS)

3-1-25. HLG KNEE

Menu item	Description	Value (factory default setting underlined)
KNEE SW	Turn ON/OFF the Knee in HLG gamma mode.	ON, <u>OFF</u>
KNEE POINT	Set the Knee point in HLG gamma mode in the units of 1%.	<u>55%</u> -- 109%
KNEE SLOPE	Set the Knee slope in HLG gamma mode.	0 -- <u>10</u> -- 100

3-1-26. WHITE CLIP

Menu item	Description	Value (factory default setting underlined)
SW	Turn ON/OFF the white clip.	ON, <u>OFF</u>
LEVEL	Set white clip level.	90% -- <u>109%</u>

3-1-27. DETAIL

Menu item	Description	Value (factory default setting underlined)
SW	Turn ON/OFF the contour correction.	ON, <u>OFF</u>
CORING	Adjust threshold level of image contour correction.	<u>0</u> -- 60
MASTER LEVEL	Adjust the contour correction level for entire image.	-31 -- <u>0</u> -- 31
FREQUENCY	Set thickness of image contour correction level.	<u>1</u> , 2 , 3

3-1-28. SKIN DETAIL

Menu item	Description	Value (factory default setting underlined)
SKIN DTL1	Select the skin color table of the object to apply the skin tone table to.	ON , <u>OFF</u>
SKIN DTL2		ON , <u>OFF</u>
SKIN DTL3		ON , <u>OFF</u>

3. MENU settings (SCENE FILE SETTINGS)

3-1-29. CHROMA

Menu item	Description	Value (factory default setting underlined)
LEVEL	Set chroma level of Pb and Pr signals.	OFF, -99% -- <u>0%</u> -- 99%

3-1-30. MATRIX

Menu item	Description	Value (factory default setting underlined)
SW	Turn ON/OFF the color matrix adjustment.	ON, <u>OFF</u>
R-G	Adjust the linear matrix	-63 -- <u>0</u> -- 63
R-B	Adjust the linear matrix	-63 -- <u>0</u> -- 63
G-R	Adjust the linear matrix	-63 -- <u>0</u> -- 63
G-B	Adjust the linear matrix	-63 -- <u>0</u> -- 63
B-R	Adjust the linear matrix	-63 -- <u>0</u> -- 63
B-G	Adjust the linear matrix	-63 -- <u>0</u> -- 63

Effect of MATRIX adjustment

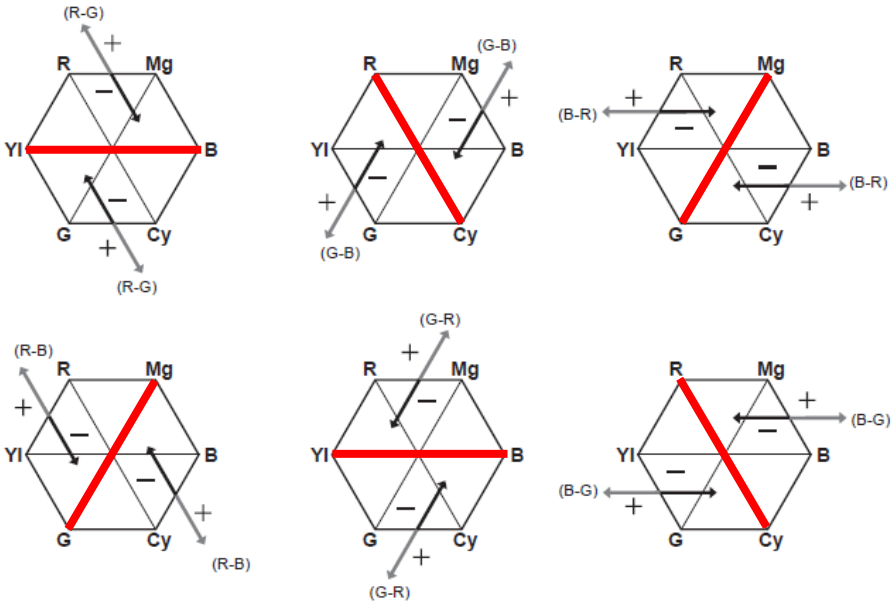

— Reference axis

3. MENU settings (SCENE FILE SETTINGS)

3-1-31. COLOR CORRECTION

Menu item	Description	Value (factory default setting underlined)
SW	Turn ON/OFF the color correction.	ON, <u>OFF</u>
PARAM	Set saturation and phase of color on 16 color axes of a picture.	-63 -- <u>0</u> -- 63

Effect of color correction

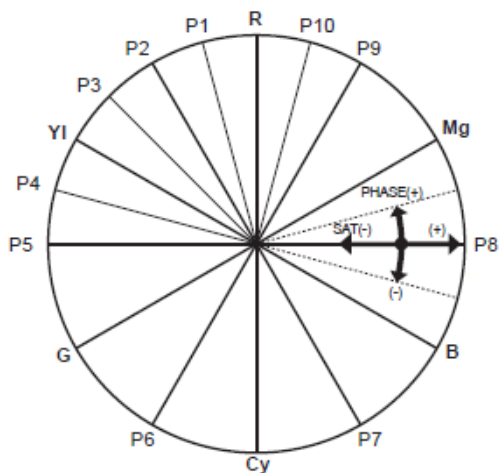

- R: Red
- P1: (YI-R)-R
- P2: (YI-R)
- P3: YI-(YI-R)
- YI: Yellow
- P4: (G-YI)-YI
- P5: (G-YI)
- G: Green
- P6: (Cy-G)
- Cy: Cyan
- P7: (B-Cy)
- B: Blue
- P8: (Mg-B)
- Mg: Magenta
- P9: (R-Mg)
- P10: R-(R-Mg)

3. MENU settings (REC SETTINGS)

3-1-32. CARDS/MEDIA

Menu item	Description	Value (factory default setting underlined)
FORMAT MEDIA	Perform SD card format.	SLOT1 , SLOT2

3-1-33. CLIP NAME

Menu item	Description	Value (factory default setting underlined)
CAM INDEX	Set the camera ID code, to be recorded as the initial letter of the clip name in MOV format.	<u>A</u> -- Z
NEXT REEL COUNT	Set the incremental reel number, to be recorded (second to fourth letter of the clip name in MOV format).	<u>001</u> -- 999

* See 5-3. File name (MOV format) (P.76) for the details.

3-1-34. 2 SLOTS FUNC.

Menu item	Description	Value (factory default setting underlined)
2 SLOT FUNC.	Set the record mode, using two SD memory cards.	OFF, <u>RELAY REC</u> , SIMUL REC

3-1-35. PRE REC

Menu item	Description	Value (factory default setting underlined)
PRE REC	Turn ON/OFF the pre-record mode. It allows the camera to capture and record video/audio from approx. 10sec before REC is started (when MAIN PIXEL setting is set to 1280x720, 1920x1080, or 2048x1080), or approx. 5 sec for other modes.	ON , <u>OFF</u>

3-1-36. REC FUNCTION

Menu item	Description	Value (factory default setting underlined)
REC MODE	Set the record mode.	<u>NORMAL</u> , INTERVAL
INTERVAL TIME	Set the interval time for interval record mode.	1s, 2s, 5s, 10s, 30s, 1min, <u>5min</u> , 10min

* INTERVAL record mode does not function when 2SLOT FUNC item is set to RELAY REC.

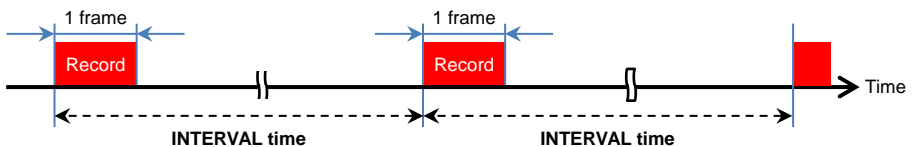

3. MENU settings (REC SETTINGS)

3-1-37. TC

Menu item	Description	Value (factory default setting underlined)
SET TC	Set the timecode value.	---
SET UB	Set the users bit information.	<u>00</u> -- FF
TC/UB/Dur.	Set the timecode display mode.	<u>TC</u> = Timecode UB = Users bit Dur. = Elapsed time of recording
FREE/REC RUN	Set the timecode count mode.	<u>FREE RUN</u> , REC RUN
DF/NDF	Set the timecode drop frame mode.	DF, <u>NDF</u>
UB MODE	Set information type, to be recorded and output from SDI OUT.	FRAME RATE Frame rate information <u>USER</u> Information, set on SET UB menu item TIME Hour, Minute, Second information DATE Year, Month, Day information CLIP NAME Clip name information
TC IN/OUT SEL	Set purpose of TC IN/OUT terminal.	<u>TC IN</u> : Use as TC input terminal TC OUT: Use as TC output terminal
TC OUT REF	Make value offset for the output timecode.	<u>RECORDING</u> : Output timecode without delay SDI OUT: Output timecode with delay so that the value meets timing with SDI OUT image

3. MENU settings (AUDIO SETTINGS)

3-1-38. AUDIO CH SETTINGS

Menu item	Description	Value (factory default setting underlined)
CH1 IN SELECT	Set audio source on the channel 1.	<u>INT(L)</u> : Built-in microphone (L) INPUT1: AUDIO INPUT1
CH2 IN SELECT	Set audio source on the channel 2.	<u>INT(R)</u> : Built-in microphone(R) INPUT1: AUDIO INPUT1 INPUT2: AUDIO INPUT2
CH1 MIC LOWCUT	Reduce the level of low frequency sound on the audio 1.	ON, <u>OFF</u>
CH2 MIC LOWCUT	Reduce the level of low frequency sound on the audio 2.	ON, <u>OFF</u>
CH1 LIMITER	Turn ON/OFF audio level limiter, when input level setting on the channel 1 is set to manual.	ON, <u>OFF</u>
CH2 LIMITER	Turn ON/OFF audio level limiter, when input level setting on the channel 2 is set to manual.	ON, <u>OFF</u>
HEAD ROOM	Set audio reference level.	18dB, 20dB

3-1-39. AUDIO INPUT

Menu item	Description	Value (factory default setting underlined)
INPUT1 LINE/MIC SEL	Set audio level of the INPUT1.	<u>LINE</u> : for audio equipment MIC: for microphone
INPUT2 LINE/MIC SEL	Set audio level of the INPUT2.	<u>LINE</u> : for audio equipment MIC: for microphone
INPUT1 MIC POWER	Turn ON/OFF +48V phantom power supply to AUDIO INPUT1.	ON, <u>OFF</u>
INPUT2 MIC POWER	Turn ON/OFF +48V phantom power supply to AUDIO INPUT2.	ON, <u>OFF</u>
INPUT1 MIC LEVEL	Set audio level of audio input 1.	-40dB, -50dB, <u>-60dB</u>
INPUT2 MIC LEVEL	Set audio level of audio input 2.	-40dB, -50dB, <u>-60dB</u>
INPUT1 LINE LEVEL	Set audio level of audio input 1.	<u>4dB</u> , 0dB
INPUT2 LINE LEVEL	Set audio level of audio input 2.	<u>4dB</u> , 0dB

3. MENU settings (AUDIO SETTINGS)

3-1-40. AUDIO OUTPUT

Menu item	Description	Value (factory default setting underlined)
MONITOR OUT	Set monitor audio output channel of phones out.	CH1, CH2, <u>STEREO</u> , MIX
MONITOR DELAY	Select audio output mode on phones out. Choose "LIVE" when delay is audible between phones out audio and actual sound.	<u>LIVE</u> , RECORDING
MONITOR VOL	Set the monitor audio level.	0 -- <u>70</u> -- 100

3-1-41. REC BEEP SOUND

Menu item	Description	Value (factory default setting underlined)
MODE	Set if make a beep sound when starting/stopping recording.	<u>OFF</u> : START: REC start only STOP: REC stop only START&STOP: Both REC start and stop
VOLUME	Set the beep sound level	HIGH, <u>MED</u> , LOW

3-1-42. ALARM

Menu item	Description	Value (factory default setting underlined)
BATTERY END	Set alert sound level of battery end.	HIGH, <u>MED</u> , LOW, OFF
MEDIA END	Set alert sound level of short card remain time.	HIGH, <u>MED</u> , LOW, OFF

3. MENU settings (OUTPUT SETTINGS)

3-1-43. SDI OUT

Image resolution of SDI OUT signal varies depends on the combination of settings, see 6-3. Output signals (SDI&HDMI) (P.80) for the details.

Menu item	Description	Value (factory default setting underlined)
OUTPUT SW	Turn ON/OFF SDI signal output.	<u>ON</u> , OFF
SIGNAL SEL	Set output signal format on the SDI OUT.	<u>SDI</u> : Vary by OUT FORMAT setting LCD(1080p): Fix at 1920X1080p LCD(1080i): Fix at 1920X1080i
OUT FORMAT	Set SDI output format.	4096X2160p, 3840x2160p, 1920x1080p, 1920x1080i, <u>1920x1080PsF</u> , 1280x720p
3G-SDI OUT	Set 3G SDI output type.	LEVEL-A, <u>LEVEL-B</u>
SDI REC REMOTE	Enable recording remote via SDI terminal.	ON, <u>OFF</u>
INDICATOR DISP	Show indicator (information of fps, audio level, etc. like LCD monitor) on the SDI OUT.	<u>ON</u> , OFF *Indicator forcedly hidden while menu screen is displayed on the LCD monitor.
MARKER DISP	Show marker (center marker, aspect marker etc.) on the SDI OUT.	ON, <u>OFF</u>
MENU DISP	Show menu characters on the SDI OUT.	<u>ON</u> , OFF

SDi signal format and output format (resolution)



OUT FORMAT	SDI FORMAT
4096x2160p	6G SDI
3840x2160p	6G SDI
1920x1080p	3G SDI
1920x1080i	1.5G SDI
1280x720p	1.5G SDI

3. MENU settings (OUTPUT SETTINGS)

3-1-44. HDMI OUT

Image resolution of HDMI OUT signal varies depends on the combination of settings, see 6-3. Output signals (SDI&HDMI) (P.80) for the details.

Menu item	Description	Value (factory default setting underlined)
SIGNAL SEL	Set output signal format on the HDMI OUT.	<u>SDI</u> : Vary by OUT FORMAT setting LCD(1080p): Fix at 1920x1080p (See. P.80)
OUT FORMAT	Set output signal format on the HDMI OUT.	4096X2160p *1 4096x2160p (420/8bit) 3840x2160p *1 3840x2160p (420/8bit) 1920x1080p 1920x1080i, 1280x720p 720x480p 720x576p *1 4:2:2 10bit
HDMI TC OUT	Add timecode information on the HDMIOUT.	ON, <u>OFF</u>
HDMI REC REMOTE	Enable recording remote via HDMI terminal.	ON, <u>OFF</u>
INDICATOR DISP	Show/hide indicator (information of fps, audio level, etc. like LCD monitor) on the HDMI OUT.	<u>ON</u> , OFF
MARKER DISP	Show marker (center marker, aspect marker etc.) on the HDMI OUT.	ON, <u>OFF</u>
MENU DISP	Show menu characters on the HDMI OUT.	<u>ON</u> , OFF

3. MENU settings (OUTPUT SETTINGS)





3-1-45. SDI/HDMI INDICATOR

Camera status information to be shown on the image can be set individually by SDI/HDMI OUTs.

Menu item	Description
CLIP NAME	Clip name
PIXEL/FREQ	System resolution and frequency for the main recorder
MAIN COLOR	COLOR (Gamma & Gamut) for the main recorder
REC FORMAT	Record codec for the main recorder
SLOT 1/2 STATUS	Status of card slots, and remaining time
2 SLOTS FUNC	Current record mode of 2SLOT function (Relay or Simul)
TC	Timecode, users bit, elapsed record time etc.
BATTERY REMAIN	Remaining battery
REC REMOTE	Status of REC/PAUSE, for equipment connected to SDI/HDMI OUTs.
AUDIO LEVEL METER	Audio level meter
FPS	Frame rate in FPS
SHUTTER	Shutter speed / open angle
EI	Exposure index
WHITE	Status of white balance adjustment
IRIS/ZOOM	Zoom position and aperture level of the lens
ND FILTER	ND filter position
E.I.S./D.ZOOM	Status of Electric Image Stabilizer (EIS) and digital zoom
WLAN	Connection status of Wi-Fi
IR SHOOTING	Status of Infrared record mode
SPOT METER	Measurement result of the spot meter in STOP / % *The unit "STOP" can be selected in V-Log mode (MENU > LCD EI ASSIST > SPOT EMTER UNIT item).

3-1-46. SDI/HDMI MARKER

Marker characters to be shown on the image can be set individually by SDI/HDMI OUTs.

Menu item	Description	Value (factory default setting underlined)
CENTER MARKER	Set shape of center marker	<u>1</u>  2  3  4  OFF
SAFETY MARKER	Set the type of safety zone marker.	1:Boxed, 2:Corner only, <u>OFF</u>
SAFETYAREA	Set the size of safety zone marker.	71.6%, 80%, <u>90%</u> , 95%
FRAME MARKER	Set the type of frame marker.	1.33:1, 1.44:1, 1.56:1, 1.78:1, 1.85:1, 2.00:1, 2.20:1, 2.35:1, 2.39:1, <u>OFF</u>
FRAME COLOR	Set the color of frame marker.	<u>WHITE</u> , BLACK, RED, GREEN, BLUE, YELLOW
PLAYBACK MARKER	Show marker characters on the playback image.	ON, <u>OFF</u>

3. MENU settings (OUTPUT SETTINGS)

3-1-47. LCD INDICATOR

Camera status information to be shown on the LCD image can be set individually.

No.	Menu item	Description
1	CLIP NAME	Clip name
2,3	PIXEL/FREQ	System resolution and frequency for the main recorder
4	MAIN COLOR	COLOR (Gamma & Gamut) for the main recorder
5	REC FORMAT	Record codec for the main recorder
6,7,8,9	SLOT 1/2 STATUS	Status of card slots, and remaining time
10	2 SLOTS FUNC	Current record mode of 2SLOT function (Relay or Simul)
11	TC	Timecode, users bit, elapsed record time etc.
12	BATTERY REMAIN	Remaining battery
26	REC REMOTE	Status of REC/PAUSE, for equipment connected to SDI/HDMI OUTs.
13	AUDIO LEVEL METER	Audio level meter

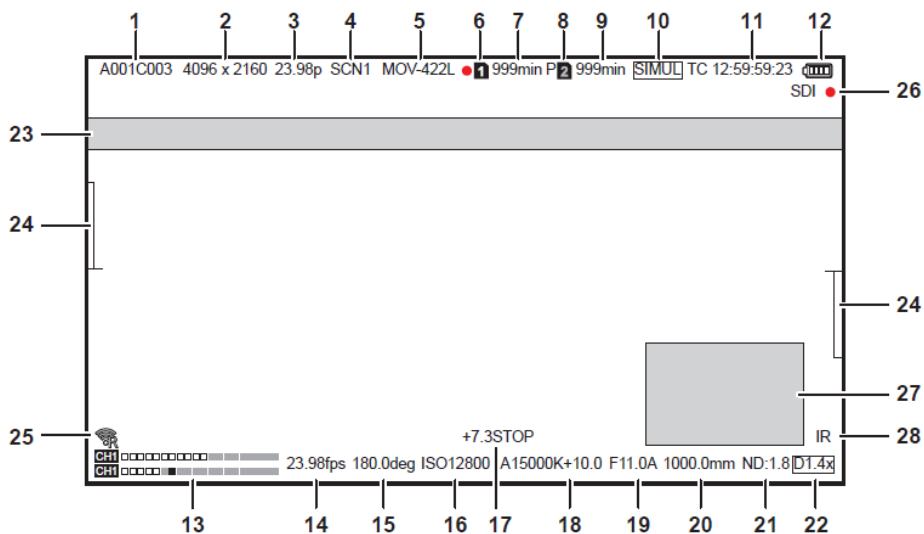

Camera status information display on the LCD monitor

3. MENU settings (OUTPUT SETTINGS)

LCD INDICATOR (continued)

Camera status information to be shown on the LCD image can be set individually.

No.	Menu item	Description
14	FPS	Frame rate in FPS
15	SHUTTER	Shutter speed / open angle
16	EI	Exposure index
18	WHITE	Status of white balance adjustment
19,20	IRIS/ZOOM	Zoom position and aperture level of the lens
21	ND FILTER	ND filter position
22	E.I.S./D.ZOOM	Status of Electric Image Stabilizer (EIS) and digital zoom
25	WLAN	Connection status of Wi-Fi
28	IR SHOOTING	Status of Infrared record mode
17	SPOT METER	Measurement result of the spot meter in STOP / % *The unit "STOP" can be selected in V-Log mode (MENU > LCD EI ASSIST > SPOT METER UNIT item).

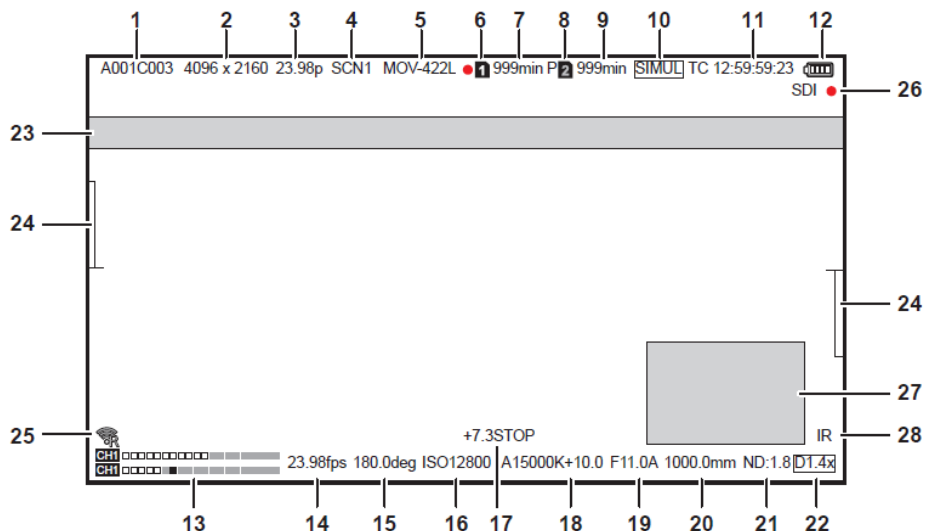





Camera status information display on the LCD monitor

3. MENU settings (OUTPUT SETTINGS)

3-1-48. LCD MARKER

Marker characters to be shown on the LCD image can be set individually.

Menu item	Description	Value (factory default setting underlined)
CENTER MARKER	Set shape of center marker	<u>1</u>  2  3  4  OFF
SAFETY MARKER	Set the type of safety zone marker.	1:Boxed, 2:Corner only, <u>OFF</u>
SAFETYAREA	Set the size of safety zone marker.	71.6%, 80%, <u>90%</u> , 95%
FRAME MARKER	Set the type of frame marker.	1.33:1, 1.44:1, 1.56:1, 1.78:1, 1.85:1, 2.00:1, 2.20:1, 2.35:1, 2.39:1, <u>OFF</u>
FRAME COLOR	Set the color of frame marker.	<u>WHITE</u> , BLACK, RED, GREEN, BLUE, YELLOW
PLAYBACK MARKER	Show marker characters on the playback image.	ON, <u>OFF</u>

3-1-49. LCD FOCUS ASSIST

Setting of focus assist related functions, available on the LCD monitor.

Menu item	Description	Value (factory default setting underlined)
EXPAND MODE	Set image expanding mode. It is assignable to any USER buttons.	10SEC: Expand for 10 seconds <u>HOLD</u> : Keep expanded until the button pressed. UNTIL REC: Expand until recording starts
EXPAND VALUE	Set image magnifying size.	<u>x2</u> , x3, x4
PEAK/SQUARES MODE	Turn ON/OFF peaking/square focus assist function.	PEAKING, <u>SQUARES</u> , PEAK/SQUARES
PEAKING LEVEL	Set highlighting level of peaking focus assist.	LOW, <u>MID</u> , HIGH
PEAKING COLOR	Set highlighting color of peaking focus assist.	<u>RED</u> , GREEN, WHITE
BLACK & WHITE	Turn ON/OFF monochrome focus assist function.	ON, <u>OFF</u> , DURING PEAK.SQUARES: Cancel color on the image while peaking/square focus assist function is enabled.
OPEN IRIS MODE	Set activation time for a focus assist function that makes focusing easier by opening aperture (by making depth of field shallower).	<u>10SEC</u> , 30SEC

3. MENU settings (OUTPUT SETTINGS)

3-1-50. LCD EI ASSIST

Settings of Exposure index control related.

Menu item	Description	Value (factory default setting underlined)
ZEBRA	Turn ON/OFF the zebra indicator on the LCD image.	ON, <u>OFF</u>
ZEBRA1 DETECT	Set the zebra pattern1. (Right downward)	0% -- <u>80%</u> -- 109%
ZEBRA2 DETECT	Set the zebra pattern2. (Right upward)	0% -- <u>100%</u> -- 109%
ZEBRA2	Set the type of light indication. See figure 3-1 below for details.	ON, SPOT, <u>OFF</u>
WFM MODE	Display waveform monitor or vector scope. (User button assignable)	<u>WAVE</u> : Display Waveform monitor (WFM) VECTOR: Display vector scope (VSC) WAVE/VECTOR: Show WFM and VSC alternately by pressing an USER button assigned the function.
WFM TRANSPARENT	Set transparency level of WFM/VSC display.	0%, <u>25%</u> , 50%
SPOT METER UNIT	Set the unit of spot meter display. "STOP" can be selected only in V-Log mode.	<u>STOP</u> , %
SPOT METER SIZE	Set detection window size of the spot meter.	S, <u>M</u> , L

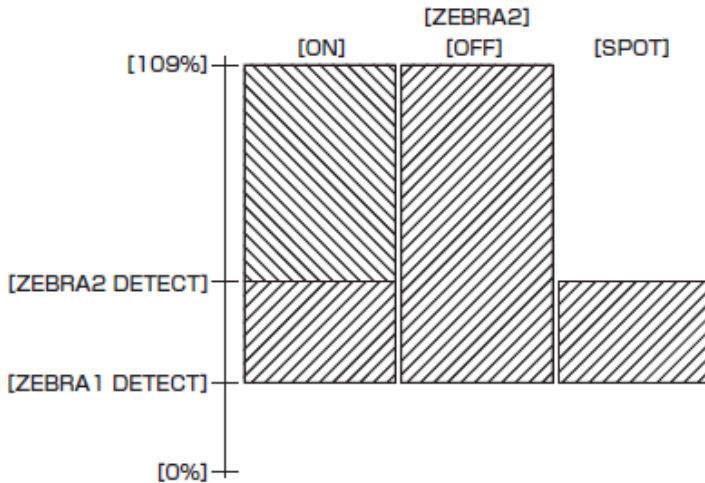

Fig.3-1 ZEBRA indication



3. MENU settings (OUTPUT SETTINGS)

3-1-51. LCD LEVELGAUGE

Settings of level gauge to be displayed on the LCD image.

Menu item	Description	Value (factory default setting underlined)
LEVEL GAUGE	Turn ON/OFF level gauge function.	<u>ON</u> , OFF
LEVEL GAUGE RESET	Set the current horizontal and vertical position as the reference point for the level gauge.	YES, NO

3-1-52. COLOR BARS

Menu item	Description	Value (factory default setting underlined)
COLOR BARS TYPE	Set color bars type.	<p>SMPTE</p> 
		<p>FULL</p> 
TEST TONE	Turn ON/OFF 1KHz tone when color bars pattern is turned ON.	<u>ON</u> , OFF

3. MENU settings (FILE)

3-1-53. SCENE FILE

Menu item	Description	Value (factory default setting underlined)
LOAD	Import custom scene files from the SD memory card.	---
SAVE	Store custom scene files to the SD memory card (overwrite to existing files).	---
SAVE AS	Store custom scene files to the SD memory card as a new file.	---

3-1-54. SETUP FILE

Menu item	Description	Value (factory default setting underlined)
LOAD	Import custom setup files from the SD memory card.	---
SAVE	Store custom setup files to the SD memory card (overwrite to existing files).	---
SAVE AS	Store custom setup files to the SD memory card as a new file.	---

3. MENU settings (NETWORK SETTINGS)

3-1-55. NETWORK SEL

Menu item	Description	Value (factory default setting underlined)
NETWORK SEL	Enable Wi-Fi mode. *Require an optional Wi-Fi adaptor.	WLAN, <u>OFF</u>

3-1-56. NETWORK FUNC

Menu item	Description	Value (factory default setting underlined)
USER ACCOUNT	Set a user account information for the Apple iPad app.	ADD, DELETE

3-1-57. NETWORK PROPERTY

Menu item	Description	Value (factory default setting underlined)
MAC ADDRESS	Display mac address information of a Wi-Fi adaptor connected.	---
TYPE	Set a connection method.	<u>DIRECT</u> Connect to Wi-Fi devices such as a tablet computer without using a wireless access point. INFRA(SELECT) Connect to a wireless access point. Access point can be chosen from an available access point list. INFRA(MANUAL) Connect to a wireless access point. Access point can be searched by entering an SSID manually.
SSID	Display network name of the AU-EVA1 unit.	---
BAND	Set connection type. (available when TYPE item is set to "DIRECT")	<u>2.4GHz</u> , 5GHz
CHANNEL (2.4GHz)	Set Wi-Fi channel of 2.4GHz network.	<u>AUTO</u> , CH1, CH6, CH11
CHANNEL (5GHz)	Set Wi-Fi channel of 5GHz network.	<u>AUTO</u> , CH36, CH40, CH44, CH48, CH100, CH104, CH108, CH112, CH116, CH132, CH136, CH140, CH149, CH153, CH157, CH161, CH165
ENCRYPTION	Set signal encryption method for INFRA connection.	WPA-TKIP, WPA-AES, WPA2-TKIP, <u>WPA2-AES</u> , NONE
ENCRYPT KEY	Set connection password.	----- *factory default password: (01234567890123456789abcdef)

3. MENU settings (NETWORK SETTINGS)

NETWORK PROPERTY (continued)

Menu item	Description	Value (factory default setting underlined)
DHCP	Set the IP address distribution method using DHCP.	OFF: Do not use DHCP CLIENT: Request the IP address to external network device. Available in INFRA(SELECT) or INFRA(MANUAL) modes. <u>SERVER</u> : Offer an IP address to a device connected to the AU-EVA1.
IP ADDRESS	Set an IP address. Available when DHCP setting is set to "OFF" or "SERVER".	<u>192.168.0.1</u>
SUBNET MASK	Set subnet mask. Available when DHCP setting is set to "OFF" or "SERVER".	<u>255.255.255.0</u>
DEFAULT GATEWAY	Set default gateway. Available when DHCP setting is set to "OFF" or "SERVER".	<u>194.168.0.254</u> *Set to 0.0.0.0 when not in use.
PRIMARY DNS	Set Primly DNS server address. Available when the TYPE item is set to "INFRA(SELECT)" or "INFRA(MANUAL)", and DHCP item is set to "OFF".	<u>0.0.0.0</u>
SECONDARY DNS	Set Secondary DNS server address. Available when the TYPE item is set to "INFRA(SELECT)" or "INFRA(MANUAL)", and DHCP item is set to "OFF".	<u>0.0.0.0</u>

3-1-58. CONNECTION HISTORY

Menu item	Description	Value (factory default setting underlined)
CONNECTION HISTORY	Display connection history with Wi-Fi access point.	<u>SELECT, DELETE</u>

3-1-59. NETWORK TOOLS

Menu item	Description	Value (factory default setting underlined)
INITIALIZE	Restore network settings to factory setting.	<u>---</u>

3. MENU settings (OPTION メニュー)

*** This menu item is not available for AU-EVA1MC and AU-EVA1EJ models. ***

3-1-60. AREA SETTINGS

Menu item	Description	Value (factory default setting underlined)
AREA SETTINGS	Change certain menu items such as DATE FORMAT, HEADROOM by area setting. See the table below for the details.	AREA1, AREA2, AREA3



Setting values by AREA SETTING

Menu item	AREA1	AREA2	AREA3
DATE FORMAT ^(*)	Y-M-D	M-D-Y	D-M-Y
HEADROOM	20dB	20dB	18dB



4. Understanding advanced features

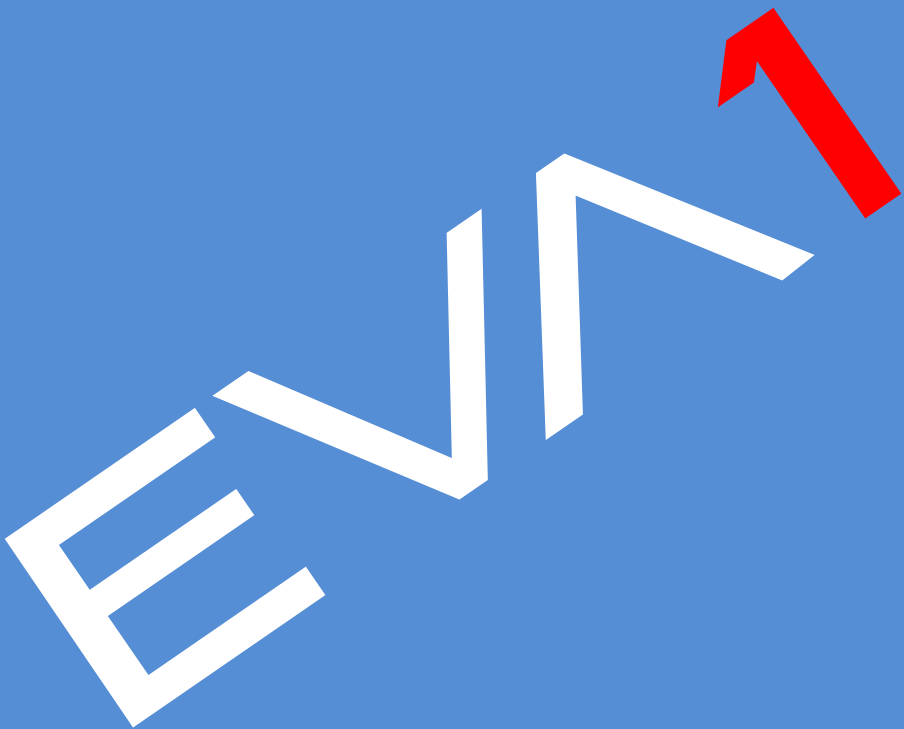

4. Understanding advanced features

4-1. Understanding Variable Frame Rate (VFR) recording

How to use

1. Set following 3 items to use the VFR function in MENU > SYSTEM SETTINGS > SYSTEM MODE. The maximum available frame rates (up to 60, 120, or 240fps) varies with the "SENSOR MODE" menu item.

Menu item	Description	Value (factory default setting underlined)
SENSOR MODE	Setting of the sensor drive mode.	<u>S35 5.7K</u> , S35 MIX 2.8K, 4/3 CROP&MIX 2.2K
MAIN PIXEL	Setting of the system resolution.	<u>4096x2160</u> , 3840, 2160, 2048x1080, 1920x1080, 1280x720
MAIN CODEC	Setting of the record codec.	MOV 420LongGOP150M, 420LongGOP100M, 420LongGOP50M, <u>422LongGOP150M</u> , 422LongGOP100M, 422LongGOP50M, 422ALL-I400M, 422ALL-I200M, 422ALL-I100M AVCHD AVCHD PS, AVCHD PH, AVCHD HA, AVCHD PM

2. Set CAMERA SETTINGS > FPS > VFR SW item to "ON"
3. Set frame rate with CAMERA SETTINGS > FPS > VALUE item.
4. Press REC button.

SENSOR MODE setting

SENSOR MODE	Active area of image sensor	Description
S35 5.7K		Use entire active plane of the imager, and generate image from all active pixels. Max frame rate 60fps
S35 MIX2.8K		Use entire active plane of the imager, and generate 2K/FHD image for horizontal 2.8K pixels by mixing pixels. Max frame rate 120fps
4/3 CROP&MIX 2.2K		Use a part of the imager for horizontal 2.2K pixels, and generate 2K/FHD image by mixing pixels. Max frame rate 240fps Angle of view becomes narrower comparing with S35 5.7K, and S35 MIX2.8K modes

4. Understanding advanced features

4-2. Monitoring image and recording

The AU-EVA1 has an HDMI 2.0 terminal and a 6G-SDI OUT, images can be output from these terminals at the same time in different resolutions. The same content display with LCD MONITOR available on the SDI OUT as the LCD crone display function.

Different image color (Gamma & Gamut preset) can individually be assigned to each output (HDMI, SDI, and LCD).

LCD MONITOR

3.5 inch LCD monitor with focus assist, and EI assist function. Touch screen.

6G-SDI OUT

- 4K30p 4:2:2 10-bit support
- 10-bit RAW support
- REC remote function
- Same content display with LCD monitor



HDMI 2.0 OUT

- 4K60p 4:2:2 10-bit support
- REC remote function
- Character superimpose

Setting SDI OUT

1. MENU > SYSTEM SETTINGS > SYSTEM MODE > FREQUENCY and MAIN PIXEL
2. MENU > OUTPUT SETTINGS > SDI OUT > SIGNAL SEL and OUT FORMAT

Setting HDMI OUT

1. MENU > SYSTEM SETTINGS > SYSTEM MODE > FREQUENCY and MAIN PIXEL
2. MENU > OUTPUT SETTINGS > HDMI OUT > SIGNAL SEL and OUT FORMAT

Image resolution of HDMI and SDI OUT signals vary depend on the system settings. See 6-3. Output signals (SDI&HDMI) (P.80) for the details.

4. Understanding advanced features

4-3. Understanding focus assist modes

The AU-EVA1 has five different focus assist modes, they can be individually recalled with USER assignable buttons (except for monochrome focus assist mode).

EXPAND

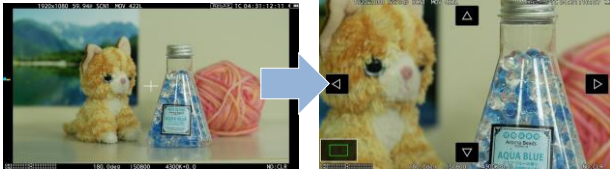

Part of image can be magnified up to 4 times (x2, x3, x4)
Its magnification period can be set from 3 different patterns below.

How to use

1. Assign “EXPAND” to one of the USER buttons. (USER 8 in factory default)
2. Set the power in MENU > OUTPUT SETTINGS > LCD FOCUS ASSIST > EXPAND VALUE [x2] [x3] [x4]
3. Set magnification period in MENU > OUTPUT SETTINGS > LCD FOCUS ASSIST > EXPAND MODE [10SEC] Magnify for 10 seconds, and return to x1 after that.
[HOLD] Keep magnified until the function is recalled with the USER button is pressed.
[UNTIL REC] Keep magnified until recording starts.
4. Press the “USER” button assigned the function.

PEAKING



Adding colored highlights to in-focus edges.
Highlighting level can be adjusted, and its color can also be selected from four different colors.

It can be used in combination with “SQUARE” focus assist mode.

How to use

1. Assign “PEAK./SQUARES F.A.” to one of the USER buttons. (USER 2 in factory default)
2. Set [PEAKING] or [PEAK/SQUARE] in MENU > OUTPUT SETTINGS > LCD FOCUS ASSIST > PEAK./SQUARES F.A.
3. Adjust its highlighting level.
MENU > OUTPUT SETTINGS > LCD FOCUS ASSIST > PEAKING LEVEL
4. Select its highlighting color
MENU > OUTPUT SETTINGS > LCD FOCUS ASSIST > PEAKING COLOR > RED, GREEN, WHITE
5. Press the “USER” button assigned the function.

4. Understanding advanced features

4-3. Understanding focus assist feature (continued)

FOCUS SQUARE

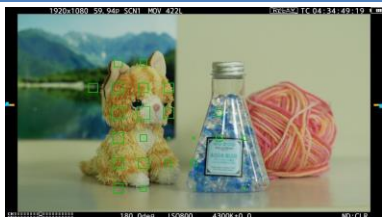

Green square boxes are displayed on the viewfinder image, whose size increases as the object behind the box comes into focus. Adjust focus ring/control so that size of the boxes over the subject/area of interest become maximum. It can be used in combination with “PEAKING” focus assist mode.

How to use

1. Assign “PEAK./SQUARES F.A.” to one of the USER buttons. (USER 2 in factory default)
2. Set [SQUARES] or [PEAK./SQUARES] in MENU > OUTPUT SETTINGS > LCD FOCUS ASSIST > PEAK./SQUARES F.A.
3. Press the “USER” button assigned the function.

OPEN IRIS

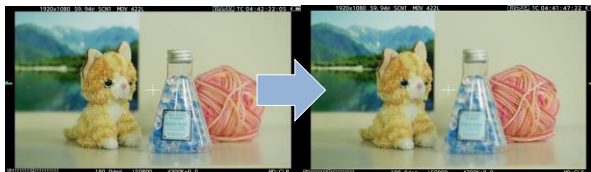

Makes focusing easier by opening aperture (i.e. by making depth of field shallower). Brightness of the image is maintained even when aperture is opened with automatic shutter speed control.

How to use

1. Assign “OPEN IRIS F.A.” to one of the USER buttons. (USER 9 in factory default)
2. Set the activation time in MENU > OUTPUT SETTINGS > LCD FOCUS ASSIST > OPEN IRIS MODE > 10SEC , 30SEC
3. Press the “USER” button assigned the function.

MONOCHROME



Makes focusing easier by canceling chrominance component on the viewfinder image.

How to use

1. MENU > OUTPUT SETTINGS > LCD FOCUS ASSIST > BLACK&WHITE > ON

4. Understanding advanced features

4-4. Understanding sport meter as Exposure Index (EI) assist

Measuring video level and stop settings to achieve desired exposure, can be performed easily with the SPOT METER function.

Overview

The graph on the figure 4-1 shows the AU-EVA1's V-Log gamma curve. It is designed to have the same characteristic as the original VARICAM's (35 and LT) curve hence, LUTs developed for VARICAM series can also be used for the AU-EVA1's footage, Please note that EVA1 exposure latitude is 14 stop while VARICAM35/LT is 14.5 stops..

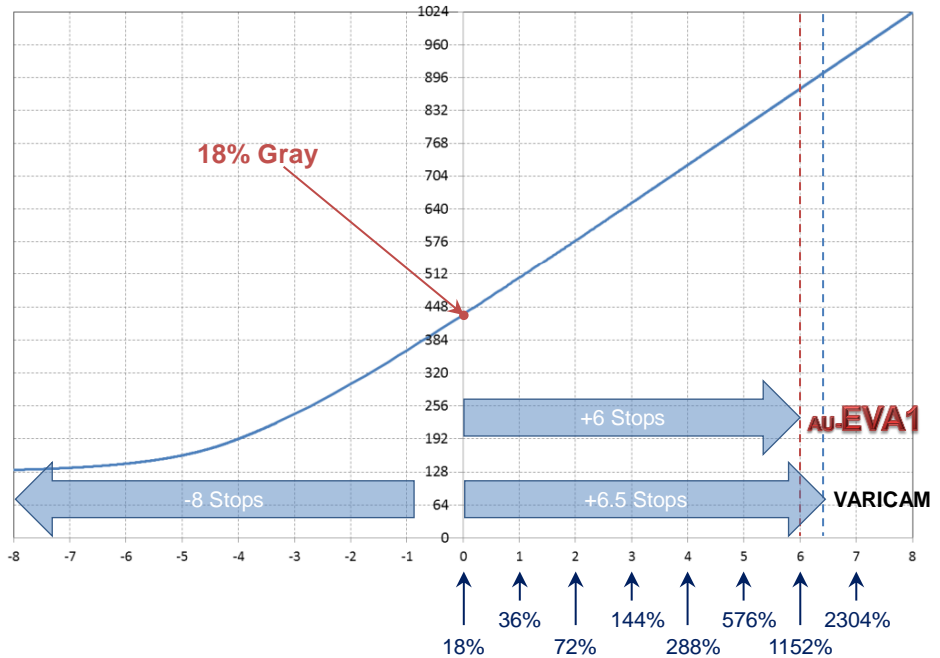

Fig.4-1 AU-EVA1's V-Log curve

10-bit code value of gray with reflection of 18% is defined as 433 (42% in IRE).

Input reflection [%]	V-Log		
	IRE [%]	10bit Code value	12bit Code value
0	7.3	128	512
18	42	433	1732
90	61	602	2408

4. Understanding advanced features

4-4. Using sport meter as Exposure Index (EI) assist

Adjusting EI with percent (%) display (example)

1. Set display unit of the spot meter function.
MENU > OUTPUT SETTINGS > LCD EI ASSIST > SPOT METER UNIT > %
2. Recall the function with one of the USER buttons (USER3 in the factory setting).
3. Position the sampling box (displayed in center of the viewfinder image) over the subject to be measured (18% gray reference for example).
4. Set the aperture, ISO, Frame rate (fps), and shutter so that the level shown on the spot meter is **42%** in “V-Log” and “V-255570L1” gamma modes, or **45%** in “V-504580L1”.

Adjusting EI with STOP display (example)

1. Set display unit of the spot meter function with the menu item below.
MENU > OUTPUT SETTINGS > LCD EI ASSIST > SPOT METER UNIT > **SPOT**
2. Recall the function with one of the USER buttons (USER3 in the factory setting).
3. Position the sampling box (displayed in center of the viewfinder image) over the subject to be measured (18% gray reference for example).
4. Set the aperture, ISO, Frame rate (fps), and shutter so that the level shown on the spot meter is **0.0STOP**.

NOTE

- * See 2-4. User assignable buttons (P.22) how to assign functions to USER buttons.
- * Size of the box (zone for measurement) can be changed in MENU > OUTPUT SETTINGS > LCD EI ASSIST > SPOT METER SIZE> S, M, L

4. Understanding advanced features

4-5. Understanding Electric Image Stabilizer (EIS) function

The AU-EVA1 is equipped with an image stabilization function that works electrically with assistance of built-in gyro sensors. The following figure illustrates the effective area of the function, and the area for motion detection and stabilizing (which is wider than the normal Super35 image area). The area to be recorded is cropped as 1/1.15 of the Super35 area.

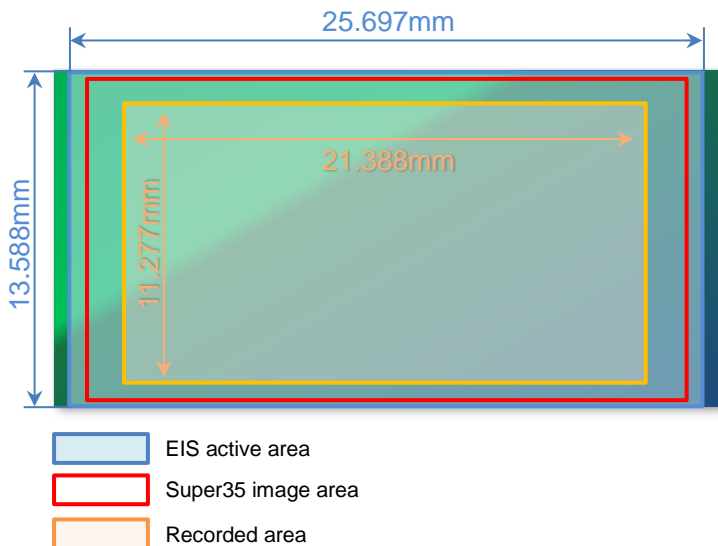

How to use

EIS related settings are in MENU > CAMERA SETTINGS > E.I.S

1. Select a way to set focal length information which is used for the reference in MENU > CAMERA SETTINGS > E.I.S > ZOOM POSITION DATA > AUTO / MANUAL.
* EF lenses that can provide focal length information to the camera are needed for AUTO detection.
2. When the ZOOM POSITION DATA item is set to "MANUAL", focal length setting can be set from 8mm to 200mm.
3. Enable the EIS function with one of the USER buttons (USER4 for the factory setting).

Note:

- Effect level becomes smaller as the frame rate decreases lower than 24fps in variable frame rate mode (see. 4-1. Understanding Variable Frame Rate (VFR) recording).
- No enough effect can be expected with the lenses whose focal length is outside the range of 8mm to 200mm.
- EIS does not function under following conditions:
 - When the sensor mode (MENU > SYSTEM SETTINGS > SYSTEM MODE > SENSOR MODE) menu item is set to "4/3CROP&MIX2.2K".
 - While digital zoom (D.ZOOM) is functioning.
 - While optical image stabilizer is working in the lens.

4. Understanding advanced features

4-6. Understanding dual memory card slot feature

SIMUL (Simultaneous)

Record the same content onto two SD memory cards simultaneously. Even if recording stops on one card unexpectedly, recording on the other card can continue.

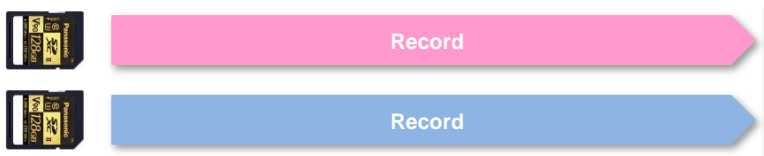

- In the case when one of the cards (in slot1 for example) becomes full and stops recording, recording also stops on another card (in slot2). To recover that, replace an SD memory card that stopped initially (slot1) and press REC button. If just pressed REC button without replacing any card, recording resumes with a card (in slot2).
- Use the same SD memory card type for speed class and capacity. Using different specification of the card may cause unexpected recording to stop.

RELAY

Recording is taken over from one to the other card. Suitable for long-duration recordings. Even if the camera is in recording, one of other card (which is not in recording) can be ejected and another mounted.

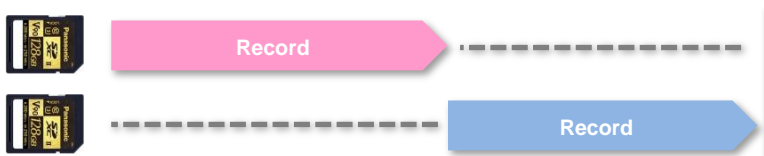

*The maximum continuous record time is 10 hours.

Using the Two-slot features.

MENU > REC SETTINGS > 2SLOT FUNC. > SIMUL REC, RELAY REC

4. Understanding advanced features

4-7. Synchronize timecode

The AU-EVA1 has a timecode IN/OUT terminal (common use for IN and OUT). The following describes workflow know-how when using timecode synchronization feature with two AU-EVA1.



Preparation

1. Connect TC IN/OUT terminals on both master and slave units with a BNC cable.
2. Make sure that the settings of the following menu item is the same for both units.

SYSTEM SETTINGS > SYSTEM MODE > FREQUENCY

Setting for master unit

4. Set MENU > REC SETTINGS > TC > TC IN/OUT SEL item to "TC OUT".
5. Set MENU > REC SETTINGS > TC > DF/NDF item to "DF" or "NDF (*1)".
*1 Selectable when FREQUENCY setting is 23.98p, 24.00p, 25.00p, 50.00p, or 50.00i.

Setting for slave unit

1. Set MENU > REC SETTINGS > TC > FREE/REC RUN item to "FREE RUN".
2. Set MENU > REC SETTINGS > TC > TC IN/OUT SEL item to "TC IN".

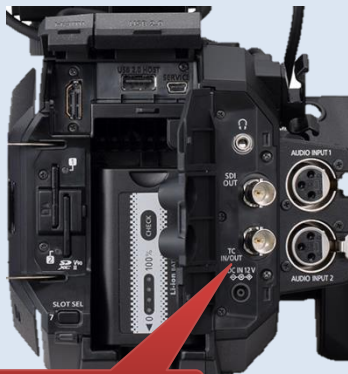

TC IN/OUT terminal

NOTE:

Since the AU-EVA1 does not have genlock feature, timecode values may differ for 1 frame from the value supplied.

The AU-EVA1 locks timecode value while the unit is in REC stand-by mode. Does not lock while in recording mode.

4. Understanding advanced features

4-8. Understanding remote operation via EVA ROP application

Remote control via Wi-Fi network is available by using an application for iPad and Android OS.

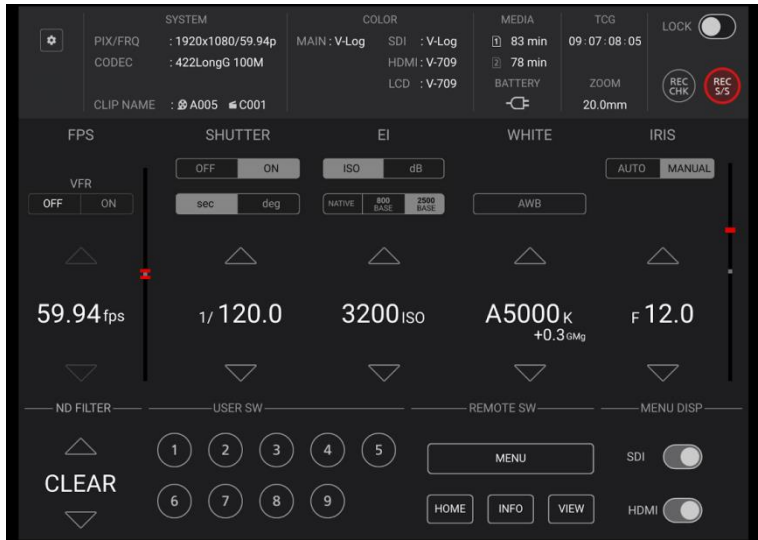

Necessary equipment

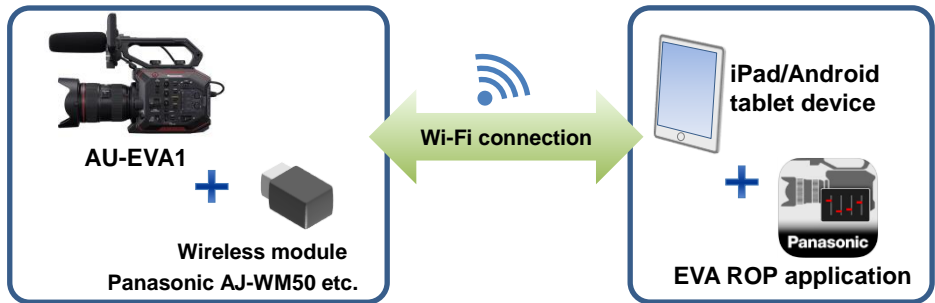

Setting up equipment (Overview)

1. Install the Panasonic EVA ROP application from Apple App Store or Google Play to the tablet device.
2. Connect the wireless module to the USB2.0 HOST terminal on the AU-EVA1.
3. Set Wi-Fi related settings on the AU-EVA1.
4. Set Wi-Fi related settings on the tablet device and connect to the AU-EVA1.
5. Open the Panasonic EVA ROP application.

4. Understanding advanced features

Set up example

Setting on AU-EVA1

1. Connect a wireless module (optional) to the USB2.0 HOST terminal.
2. Set following USB related menu items to enable the USB port for EVA ROP connection.
MENU > NETWORK SETTINGS > NETWORK SEL > WLAN
3. Set network related menu items in MENU > NETWORK SETTINGS > NETWORK PROPERTY.



Menu item	Value
TYPE	DIRECT
SSID	Enter SSID name (Default: AU-EVA1)
BAND	Choose " 2.4GHz " or " 5GHz " depends on Wi-Fi adaptor type.
CHANNEL(2.4GHz)	AUTO
CHANNEL(5GHz)	AUTO
ENCRYPT KEY	Enter connection password used to connect to the AU-EVA1 from the tablet device. (Default: 01234567890123456789abcdef)
DHCP	SERVER
IP ADDRESS	Default: 192.168.0.1
SUBNET MASK	Default: 255.255.255.0
DEFAULT GATEWAY	Default: 192.168.0.254

4. Set an account in MENU > NETWORK SETTINGS > NETWORK FUNK

Menu item	Value
USER ACCOUNT	Set an account (ID name and its password) used for authentication from EVA ROP. (Default ID: guest , password: august)

4. Understanding advanced features

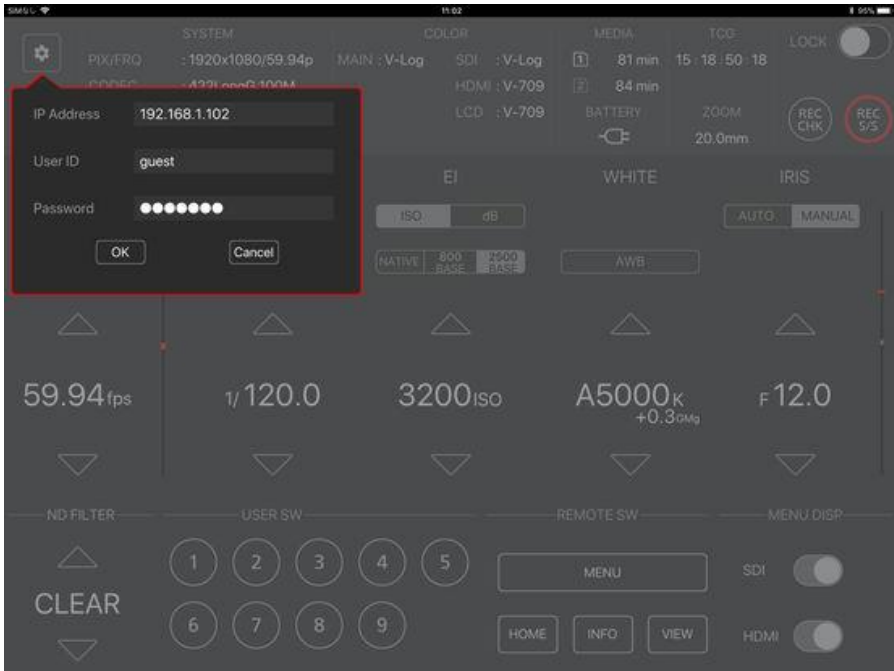

Setting on tablet device (on iPad for example)

1. Install the Panasonic EVA ROP app from App Store.
2. Open "Setting"  > Wi-Fi > ", and choose an SSID of the AU-EVA1 (example AU-EVA1).
3. Enter connection password (factory default: 01234567890123456789abcdef) to connect to the AU-EVA1 via Wi-Fi network.
4. Open the Panasonic EVA ROP app on the iPad. Tap  symbol and complete authentication settings by entering "IP address, user ID (factory setting: guest), and password (factory setting: august) of the AU-EVA1.
5. Confirm that the connection status of the AU-EVA1 is shown as  (ready to be controlled from the app.).
6. Start operation from the app.



Panasonic EVA ROP application for iPad

Connection status on the AU-EVA1

	No connection
	Connected to a Wi-Fi device (iPad/Android device, Wi-Fi access point etc.)

4. Understanding advanced features

4-9. Understanding RAW output feature

10-bit RAW data output is available for the greatest flexibility in post image adjustment. The RAW data is output from SDI OUT (RAW data cannot be recorded with the built-in recorder in the EVA1).

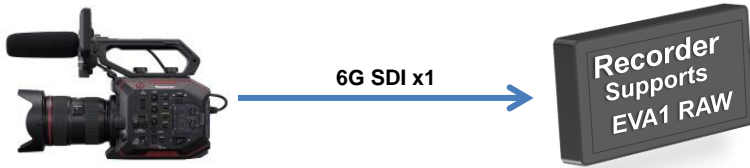

Settings to use RAW data output

1. Set output mode in MENU > SYSTEM SETTINGS > SYSTEM MODE > SDI RAW item.
Available maximum frame rate for variable frame rate record (VFR) and view angle vary as described in the chart below.

SDI RAW menu	Description	Max. fps
S35 5.7K	Use entire active plane of the imager, and output RAW data from all active pixels (5760x3072).	30fps
CROP 4K	Use a part of the imager, and output RAW data from all active pixels within the part (4096x2160).	60fps
CROP&MIX 2K	Use a part of the imager, and generate RAW data (2048x1080) by mixing pixels.	240fps

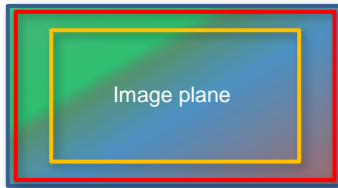

- S35 5.7K
- CROP 4K, CROP&MIX 2K

2. Connect a recorder (support EVA1's RAW data record) to SDI OUT and record.

*Output data resolution and maximum available frame rate (for variable frame rate record mode) vary by settings in the chart below.

FREQUENCY	SDI RAW	VFR
23.98p, 24.00p, 29.97p	S35 5.7K (5760x3072 pixels)	1 – 30fps
	CROP 4K (4096x2160 pixels)	1 – 60fps
	CROP&MIX 2K (2048x1080 pixels)	1 – 240fps
25.00p	S35 5.7K (5760x3072 pixels)	1 – 25fps
	CROP 4K (4096x2160 pixels)	1 – 50fps
	CROP&MIX 2K (2048x1080 pixels)	1 – 200fps
50.00p	CROP 4K (4096x2160 pixels)	1 – 50fps
	CROP&MIX 2K (2048x1080 pixels)	1 – 200fps
59.94p	CROP 4K (4096x2160 pixels)	1 – 60fps
	CROP&MIX 2K (2048x1080 pixels)	1 – 240fps
59.94i, 50.00i	No RAW data out available	

4. Understanding advanced features

4-10. Updating firmware

1. Download firmware package from the support website at https://panasonic.biz/cns/sav/pass_e
2. Unzip the package and copy "UPDATE.HDC" file to the **ROOT (the top-most) directory** in the SD memory card.

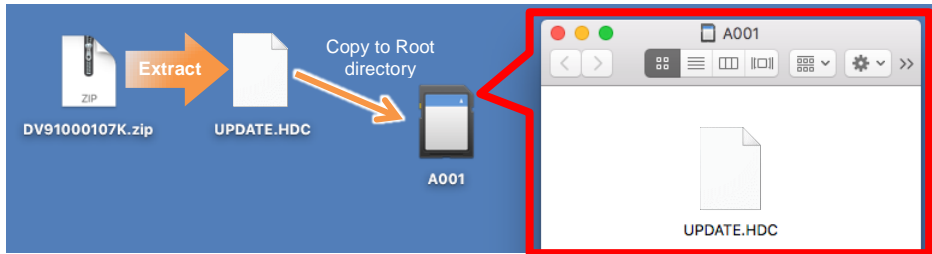

3. Mount the SD memory card to the **SLOT1 (Not SLOT2)** in the EVA1.
4. Execute update (**MENU > SYSTEM SETTINGS > INFORMATION > UPDATE > YES**).

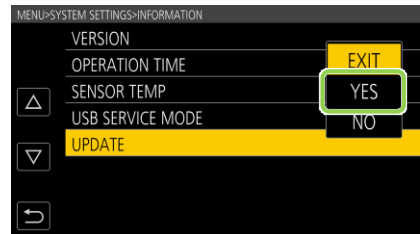
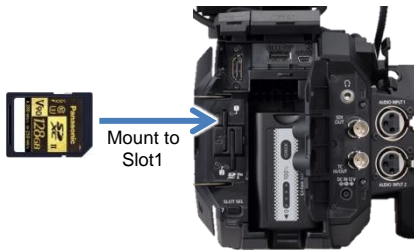

5. Make sure the version in **MENU > SYSTEM SETTINGS > INFORMATION > VERSION**.

Troubleshoot

Error message on EVA1	Check points
<p>CHECK CARD.</p>	<ul style="list-style-type: none"> • Is the file name of the firmware on the SD card surely "UPDATE.HDC"? Renamed files (for example: UPDATE.HDC2, UPDATE.HDC-1, etc.) are not accepted. • Is the SD card surely mounted to the Slot1? Update cannot be performed in the Slot2. • Is the UPDATE.HDC file surely copied to the root directory of the SD card?
<p>FORMAT ERROR CARD <SLOT 1></p>	<ul style="list-style-type: none"> • It occurs when intend to use SD cards formatted with PC/Mac and other equipment than EVA1. Please use SD cards formatted with the EVA1.

5. File format



5. File format

5-1. Folder structure in the record media

Folder structure example

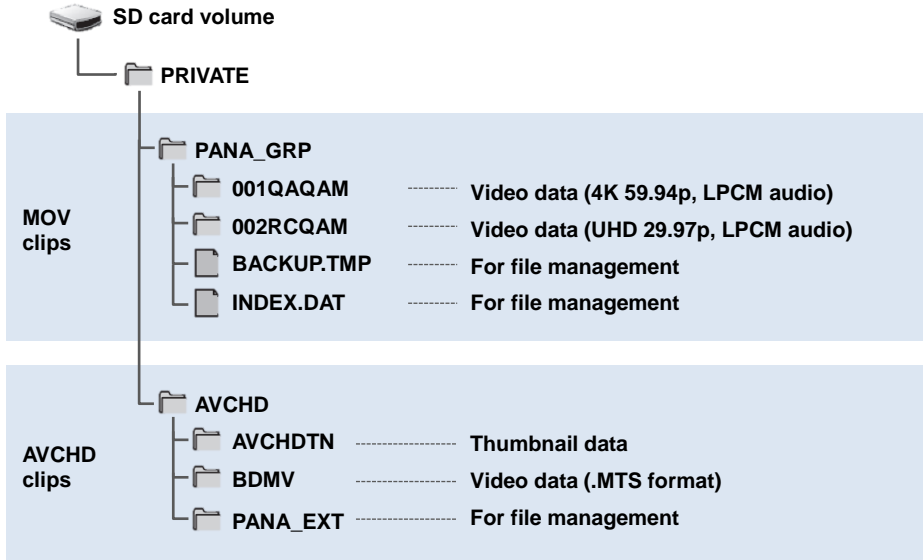

Caution

Several kind of different files are stored under PRIVATE folder. Always copy the PRIVATE folder as a file set. Copying .MTS, .MOV files only may cause clip to be unplayable.

5. File format

5-2. Folder name (MOV format)

Folders storing MOV clips are named depends on resolution, frame rate, video format, and other settings below.

Example

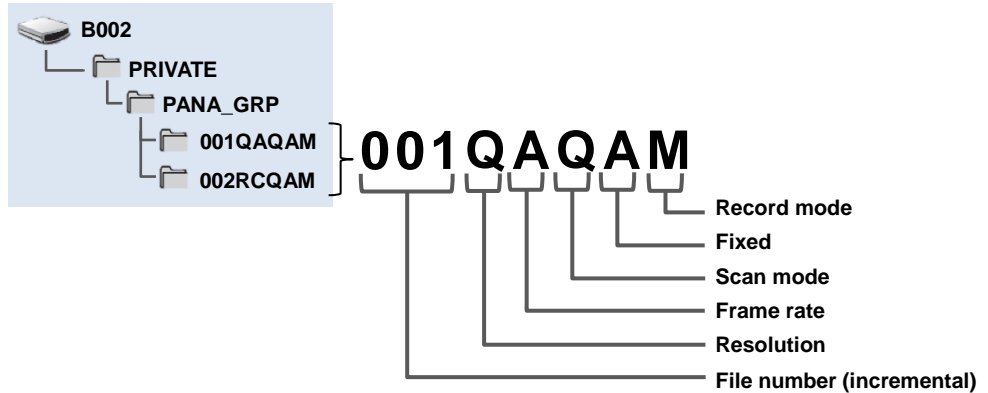

Example: a folder is named as “001QAQAM”

This folder contains clips with 4096x2160 resolution, 59.94fps frame rate, and MOV, LPCM format in progressive scan mode.

Resolution	Frame rate (fps)	Scan mode	Record mode
Q:4096x2160 R:3840x 2160 P:2048x1080 Y:1920x1080	A: 59.94 B: 50.00 C: 29.97 D: 25.00 E: 24.00 F: 23.98	Q:Progressive scan (with LPCM audio) J:Interlace scan (with LPCM audio)	T: Simul record mode M: Normal record mode

5. File format

5-3. File name (MOV format)

The AU-EVA1 supports 20-digits cine style clip naming for MOV clips as the same structure with VARICAM series (AU-V35LT1G etc.) for easy clip management.

Example of cine style file name

B002C010-170918-E125.mov

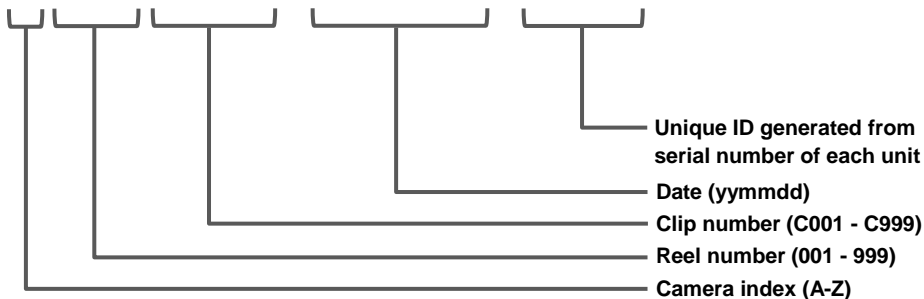

Camera index (A to Z)	It can be assigned in MENU > REC SETTINGS > CLIP NAME > CAM INDEX.
Reel number (001 to 999)	Increments by SD memory card, the three digits index is named as SD card's volume label.
Clip number (C001 to C999)	Increments by recording. Its number count returns to C001 when format a SD card. Its number incrementing goes on even when folder is separated.
Date	yymmdd format
Unique ID	Numbers and alphabets, four letters in total

Caution



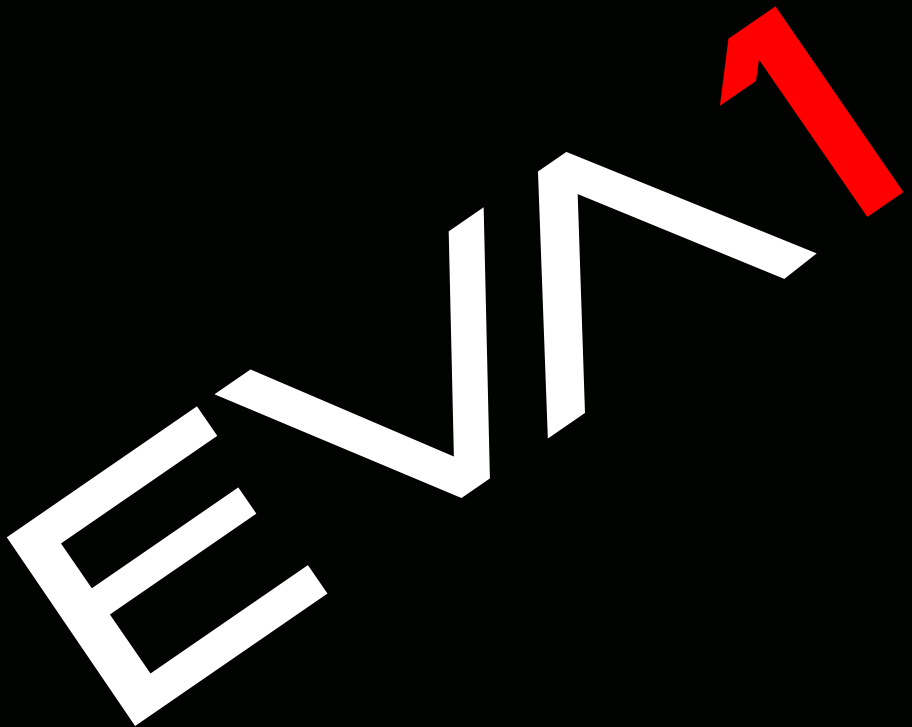

- In the SIMUL (simultaneous) record mode, the same clip name is given to the SD card in the both slot1 and slot2.
- The maximum number of recordable clips in a folder is 999.
- The maximum number of recordable clips in an SD card is approximately 4000 clips.

6. Appendix



6. Appendix

6-1. Battery runtime

Part number	Voltage & capacity (Minimum)	Hours to charge ^{*1}	Operation time ^{*2}
 VW-VBR59 (comes standard/optional)	7.28V 5900mAh, 43Wh	3h 20min	2h 50min
 VW-VBR89G (Optional)	7.28V 8850mAh, 64Wh	4h 00min	4h 15min
 VW-VBR118G (Optional)	7.28V 11800mAh, 86Wh	4h 40min	5h 40min
 VW-VBD58 (Optional)	7.2V 5800mAh, 42Wh	5h 20min	2h 40min

*1 Charging times are measured at an ambient temperature of 25°C / 77.0°F, and relative humidity at 60%, using the battery charger that comes standard with product. N.B. it may vary under different conditions.

*2 Operation times are measured under following conditions, Times may vary under different conditions.

- Menu settings, factory default.
- Remote operation grip connected, no any other cables are connected to any IN/OUT terminals.

6. Appendix

6-2. Scene file preset

Menu item		MAIN				
		SCENE1	SCENE2	SCENE3	SCENE4	SCENE5
BLACK	M.PED	0	2	8	8	1
	R PED	0	0	0	0	0
	G PED	0	0	0	0	0
	B PED	0	0	0	0	0
	PEDESTAL OFFSET	OFF	OFF	OFF	OFF	OFF
GAMMA	GAMMA SELECT	V255570L1	V504580L1	VIDEO	VIDEO	HLG
	MASTER GAMMA	*1	*1	0.45	0.50	*1
	BLACK GAMMA	*2	*2	OFF	OFF	OFF
	B.GAMMA RANGE	*2	*2	1	1	1
KNEE	KNEE SW	*1	*1	ON	ON	*1
	KNEE MODE			D RANGE	D RANGE	
	KNEE POINT			90%	93%	
	KNEE SLOPE			100	100	
HLG KNEE	KNEE SW	*3	*3	*3	*3	OFF
	KNEE POINT					55
	KNEE SLOPE					10
WHITE CLIP	SW	*1	*1	OFF	OFF	*1
	LEVEL			109%	109%	
DETAIL	SW	OFF	OFF	ON	ON	OFF
	CORING	0	0	0	0	0
	MASTER LEVEL	0	0	0	0	0
	FREQUENCY	1	1	1	1	1
SKIN DETAIL	SKIN DTL1	OFF	OFF	OFF	OFF	OFF
	SKIN DTL2	OFF	OFF	OFF	OFF	OFF
	SKIN DTL3	OFF	OFF	OFF	OFF	OFF
CHROMA	LEVEL	0%	0%	0%	15%	0%
MATRIX	SW	OFF	OFF	OFF	OFF	OFF
	(R-G)	0	0	0	0	0
	(R-B)	0	0	0	0	0
	(G-R)	0	0	0	0	0
	(G-B)	0	0	0	0	0
	(B-R)	0	0	0	0	0
	(B-G)	0	0	0	0	0

*1 Available when GAMMA SELECT setting is set to "VIDEO".

*2 Available when GAMMA SELECT setting is set to "VIDEO" or "HLG".

*3 Available when GAMMA SELECT setting is set to "HLG".

6. Appendix

6-3. Output signals (SDI&HDMI)

SDI OUT

Image resolution of SDI OUT signal varies depends on the combination of settings below.

**MENU > SYSTEM SETTINGS > SYSTEM MODE > FREQUENCY and MAIN PIXEL
MENU > OUTPUT SETTINGS > SDI OUT > SIGNAL SEL and OUT FORMAT**

MENU SETTING			SIGNAL OUT FORMAT (OUT FORMAT MENU ITEM)	
FREQUENCY	MAIN PIXEL	SIGNAL SEL		
59.94p 50.00p	4096x2160	SDI	1920x1080p *1, <u>1920x1080i</u> *1	
		LCD (1080p)	1920x1080p *2	
		LCD (1080i)	1920x1080i *2	
	3840x2160	SDI	1920x1080p, <u>1920x1080i</u>	
		LCD (1080p)	1920x1080p *2	
		LCD (1080i)	1920x1080i *2	
	2048x1080	SDI	1920x1080p *1, <u>1920x1080i</u> *1	
		LCD (1080p)	1920x1080p *2	
		LCD (1080i)	1920x1080i *2	
	1920x1080	1920x1080	SDI	1920x1080p, <u>1920x1080i</u>
			LCD (1080p)	1920x1080p *2
			LCD (1080i)	1920x1080i *2
1280x720		SDI	<u>1280x720p</u>	
		LCD (1080p)	1920x1080p *2	
		LCD (1080i)	1920x1080i *2	
59.94i 50.00i	1920x1080	SDI	<u>1920x1080i</u>	
		LCD (1080p)	1920x1080p *2	
		LCD (1080i)	1920x1080i *2	
29.97p 23.98p	4096x2160	SDI	4096x2160p, 1920x1080p *1, <u>1920x1080PsF</u> *1	
		LCD (1080p)	1920x1080 over 59p *2	
		LCD (1080i)	1920x1080 over 59i *2	
	3840x2160	SDI	3840x2160p, 1920x1080p, <u>1920x1080PsF</u>	
		LCD (1080p)	1920x1080 over 59p *2	
		LCD (1080i)	1920x1080 over 59i *2	
	2048x1080	SDI	1920x1080p *1, <u>1920x1080PsF</u> *1	
		LCD (1080p)	1920x1080 over 59p *2	
		LCD (1080i)	1920x1080 over 59i *2	
	1920x1080	SDI	1920x1080p, <u>1920x1080PsF</u>	
		LCD (1080p)	1920x1080 over 59p *2	
		LCD (1080i)	1920x1080 over 59i *2	

*1 Displayed as letterbox format, image quality may slightly be lower than image recorded.

*2 LCD clone mode, focus and EI assist characters can be displayed, image sampling and bit-depth becomes 4:2:2 8-bit, blank panels (at top, bottom, left, and right) are always displayed.

6. Appendix

6-3. Output signals (SDI&HDMI)

SDI OUT

Image resolution of SDI OUT signal varies depends on the combination of settings below.

**MENU > SYSTEM SETTINGS > SYSTEM MODE > FREQUENCY and MAIN PIXEL
MENU > OUTPUT SETTINGS > SDI OUT > SIGNAL SEL and OUT FORMAT**

MENU SETTING			SIGNAL OUT FORMAT (OUT FORMAT MENU ITEM)
FREQUENCY	MAIN PIXEL	SIGNAL SEL	
24.00p	4096x2160	SDI	4096x2160p, 1920x1080p *1, <u>1920x1080PsF</u> *1
		LCD (1080p)	1920x1080 over 60p *2
		LCD (1080i)	1920x1080 over 60i *2
	2048x1080	SDI	1920x1080p *1, <u>1920x1080PsF</u> *1
		LCD (1080p)	1920x1080 over 60p *2
		LCD (1080i)	1920x1080 over 60i *2
25.00p	4096x2160	SDI	4096x2160p, 1920x1080p *1, <u>1920x1080PsF</u> *1
		LCD (1080p)	1920x1080 over 50p *2
		LCD (1080i)	1920x1080 over 50i *2
	3840x2160	SDI	3840x2160p, 1920x1080p, <u>1920x1080PsF</u>
		LCD (1080p)	1920x1080 over 50p *2
		LCD (1080i)	1920x1080 over 50i *2
	2048x1080	SDI	1920x1080p *1, <u>1920x1080PsF</u> *1
		LCD (1080p)	1920x1080 over 50p *2
		LCD (1080i)	1920x1080 over 50i *2
	1920x1080	SDI	1920x1080p, <u>1920x1080PsF</u>
		LCD (1080p)	1920x1080 over 50p *2
		LCD (1080i)	1920x1080 over 50i *2

*1 Displayed as letterbox format, image quality may slightly be lower than image recorded.

*2 LCD clone mode, focus and EI assist characters can be displayed, image sampling and bit-depth becomes 4:2:2 8-bit, blank panels (at top, bottom, left, and right) are always displayed.

6. Appendix

6-3. Output signals (SDI&HDMI)

HDMI OUT

Image resolution of HDMI OUT signal varies depends on the combination of settings below.

**MENU > SYSTEM SETTINGS > SYSTEM MODE > FREQUENCY and MAIN PIXEL
MENU > OUTPUT SETTINGS > HDMI OUT > SIGNAL SEL and OUT FORMAT**

MENU SETTINGS			SIGNAL OUT FORMAT (OUT FORMAT MENU ITEM)
FREQUENCY	MAIN PIXEL	SIGNAL SEL	
59.94p 50.00p	4096x2160	HDMI	4096x2160p, 4096x2160p (4:2:0 8bit), 1920x1080p *3, 1920x1080i *3
		LCD(1080p)	1920x1080p *4
	3840x2160	HDMI	3840x2160p, 3840x2160p (4:2:0 8bit), 1920x1080p, 1920x1080i
		LCD(1080p)	1920x1080p *4
	2048x1080	HDMI	1920x1080p *3, 1920x1080i *3
		LCD(1080p)	1920x1080p *4
	1920x1080	HDMI	1920x1080p, 1920x1080i
		LCD(1080p)	1920x1080p *4
	1280x720	HDMI	1280x720p
		LCD(1080p)	1920x1080p *4
59.94i	1920x1080	HDMI	1920x1080i, 720x480p
		LCD(1080p)	1920x1080p *4
50.00i	1920x1080	HDMI	1920x1080i, 720x576p
		LCD(1080p)	1920x1080p *4
29.97p 23.98p	4096x2160	HDMI	4096x2160p, 1920x1080p *3
		LCD(1080p)	1920x1080 over 59.94p *4
	3840x2160	HDMI	3840x2160p, 1920x1080p
		LCD(1080p)	1920x1080 over 59.94p *4
	2048x1080	HDMI	1920x1080p *3
		LCD(1080p)	1920x1080 over 59.94p *4
1920x1080	HDMI	1920x1080p	
	LCD(1080p)	1920x1080 over 59.94p *4	
24.00p	4096x2160	HDMI	4096x2160p, 1920x1080p *3
		LCD(1080p)	1920x1080 over 60p *4
	2048x1080	HDMI	1920x1080p *3
		LCD(1080p)	1920x1080 over 60p *4

*3 Displayed as letterbox format, image quality may slightly be lower than image recorded.

*4 LCD clone mode, focus and EI assist characters can be displayed, image sampling and bit-depth becomes 4:2:2 8-bit, blank panels (at top, bottom, left, and right) are always displayed.

6. Appendix

6-3. Output signals (SDI&HDMI)

HDMI OUT

Image resolution of HDMI OUT signal varies depends on the combination of settings below.

**MENU > SYSTEM SETTINGS > SYSTEM MODE > FREQUENCY and MAIN PIXEL
MENU > OUTPUT SETTINGS > HDMI OUT > SIGNAL SEL and OUT FORMAT**

MENU SETTINGS			SIGNAL OUT FORMAT (OUT FORMAT MENU ITEM)
FREQUENCY	MAIN PIXEL	SIGNAL SEL	
25.00p	4096x2160	HDMI	4096x2160p, <u>1920x1080p</u> *3
		LCD(1080p)	1920x1080 over 50p *4
	3840x2160	HDMI	3840x2160p, <u>1920x1080p</u>
		LCD(1080p)	1920x1080 over 50p *4
	2048x1080	HDMI	<u>1920x1080p</u> *3
		LCD(1080p)	1920x1080 over 50p *4
	1920x1080	HDMI	<u>1920x1080p</u>
		LCD(1080p)	1920x1080 over 50p *4

*3 Displayed as letterbox format, image quality may slightly be lower than image recorded.

*4 LCD clone mode, focus and EI assist characters can be displayed, image sampling and bit-depth becomes 4:2:2 8-bit, blank panels (at top, bottom, left, and right) are always displayed.

6. Appendix





6-4. Error and warning system

When the AU-EVA1 detects any error or system trouble, the camera alerts is indicated on the LCD monitor (HOME and VIEW screen), and the tally lamp.

SYSTEM ERROR

Screen display		Description	Behavior and cause
VIEW screen	HOME screen		
[SYSTEM ERROR]	—	An error in the standard signal or communication error has occurred.	All the tally lamps and the card access lamps (orange) will flash four times a second, and an alarm is sounded. <ul style="list-style-type: none"> • Set the power to <P> (standby).

WARNING









Screen display		Description	Behavior and cause
VIEW screen	HOME screen		
[LOW BATTERY]	—	Remaining battery capacity is insufficient.	All the tally lamps and the card access lamps (orange) will flash four times a second, and an alarm is sounded. The power status display becomes  , and it will flash once every second in red. <ul style="list-style-type: none"> • The power is turned off in approximately five seconds. • Replace with a fully charged battery, or connect the AC adaptor.
[HIGH TEMPERATURE]	—	Displayed when the internal temperature of the camera has risen above assumed.	All the tally lamps and the card access lamps (orange) will flash four times a second, and an alarm is sounded. <ul style="list-style-type: none"> • The power is turned off in approximately five seconds. • Turn on the power again and check recording and playback operations. If the problem persists, consult the dealer.
[REC WARNING]		An error of the recording data has occurred during recording, and the recording has stopped.	All the tally lamps and the card access lamps (orange) will flash four times a second, and an alarm is sounded. <ul style="list-style-type: none"> • Recording is stopped.
[REC WARNING]		It has tried to record exceeding the maximum number of clips during recording.	All the tally lamps and the card access lamps (orange) will flash four times a second, and an alarm is sounded. <ul style="list-style-type: none"> • Recording is stopped. • When [DIAGNOSTICS] is selected in the INFO screen, [REC WARNING] [<OVER MAX NUM. OF CLIPS>] is displayed in the warning display area. • Replace the SD card or delete unnecessary clips.
[CARD ERROR <SLOT 1->] [CARD ERROR <SLOT 2->]		A data error caused by the SD card has occurred during recording or playback.	<ul style="list-style-type: none"> • When it was recording All the tally lamps and the card access lamps (orange) will flash four times a second, and an alarm is sounded. Recording is stopped. After the recording is stopped, the SD card where the error has occurred is write protected. Replace the SD card in the card slot where the error occurred. • When it was playing back Playback is stopped.
[END] (SD card status display)	—	The remaining recordable capacity of the SD card has exhausted during recording.	All the tally lamps and the card access lamps (orange) will flash four times a second, and an alarm is sounded. <ul style="list-style-type: none"> • Recording is stopped. • Replace the SD card or delete unnecessary clips.
 (Once every second, flash in red)	—	Battery is almost consumed.	All the tally lamps will flash once every second. <ul style="list-style-type: none"> • The current operation will continue. • Replace with a fully charged battery, or connect the AC adaptor.
SD card remaining recordable capacity display (Flashes once every second during recording)	—	The remaining recordable capacity of the SD is getting low.	<ul style="list-style-type: none"> • Recording will continue. • Replace the SD card as necessary.

6. Appendix

6-4. Error and warning system

When the AU-EVA1 detects any error or system trouble, the camera alerts is indicated on the LCD monitor (HOME and VIEW screen), and the tally lamp.

ALERT

Screen display		Description	Behavior and cause
VIEW screen	HOME screen		
[SIMUL REC WARNING <SLOT 1>] [SIMUL REC WARNING <SLOT 2>]		An error has occurred in one of the SD card during simultaneous recording.	A message is displayed for approximately five seconds. • Recording to the other SD card will continue.
[SIMUL REC WARNING <SLOT 1>] [SIMUL REC WARNING <SLOT 2>]		It has tried to record exceeding the maximum number of clips to one of the SD card during simultaneous recording.	A message is displayed for approximately five seconds. • Recording to the other SD card will continue. • When [DIAGNOSTICS] is selected in the INFO screen, [SIMUL REC WARNING] [-OVER MAX NUM. OF CLIPS>] is displayed in the warning display area. • Replace the SD card or delete unnecessary clips.
[FAN STOPPED]		The fan has stopped.	A message is displayed. • The current operation will continue. • Stop the use immediately when the fan has stopped, and consult the dealer. • If the fan has stopped, temperature of the camera will rise. Therefore, do not use the camera for a long period of time.
[CHECK CARD <SLOT 1>] [CHECK CARD <SLOT 2>]		The card cannot be recognized properly because a recording medium which is not supported has been inserted or there is dirt on the terminal of the card.	A message is displayed for approximately five seconds. • Check the card that is inserted.
[FORMAT ERROR CARD <SLOT 1>] [FORMAT ERROR CARD <SLOT 2>]		The SD card with management information that is out of specification is inserted. (Include when the system frequency (59.94 Hz system or 50 Hz system) for the AVCHD format in the SD card is different from the setting in the [SYSTEM SETTINGS] menu → [SYSTEM MODE] → [FREQUENCY])	A message is displayed for approximately five seconds. • Insert an SD card that can be recorded. • The system frequency information for the AVCHD format is confirmed at the time of formatting or at the first recording.
[NOT SDXC CARD <SLOT 1>] [NOT SDXC CARD <SLOT 2>]		The SDHC memory card that cannot record the MOV format data is inserted when [MAIN CODEC] is set to MOV format.	A message is displayed for approximately five seconds. • Insert an SDXC memory card.
[INCOMPATIBLE CARD <SLOT 1>] [INCOMPATIBLE CARD <SLOT 2>]		The SD card that may not be able to record due to slow writing speed is inserted.	A message is displayed for approximately five seconds. • The current operation will continue. • Use an SD card with sufficient writing speed.
[BACKUP BATT EMPTY]		Voltage lowering of the backup battery for internal clock was detected when the power is set to <1> (ON).	A message is displayed for approximately five seconds. • The current operation will continue. • Set the date/time again after charging the built-in battery.

6. Appendix

6-4. Error and warning system

MESSAGE

Screen display		Description	Behavior and cause
VIEW screen	HOME screen		
[CANNOT PLAY.]	—	This is a clip that cannot be played back. (When it cannot be played back due to difference of the system frequency, etc.) An error has occurred during playback, and the playback has stopped.	A message is displayed. • Confirm if the system frequency of the clip is the same as the system frequency of the camera. • Check the clip.
[CANNOT DELETE.]	—	This is a clip that cannot be deleted.	A message is displayed. • Match the device and content versions.
[CANNOT RECORD. THE NUMBER OF CLIPS HAS EXCEEDED THE MAXIMUM LIMIT.]	—	The number of clips that can be recorded has reached the maximum.	A message is displayed. • Replace the SD card or delete unnecessary clips.
[CARD ERROR. PLEASE REFORMAT.]	—	Formatting of the SD card has failed.	A message is displayed. • Format it again.
[Repair failed.]	—	Repairing of the clip that an error has occurred has failed due to disconnection of the power or removing of the SD card during recording. Restoring of the management information has failed.	A message is displayed. • Check the SD card.
[UNABLE TO FORMAT.]	—	This is an SD card that cannot be formatted.	A message is displayed. • Check the SD card.
[CANNOT REPAIR CONTROL INFORMATION DUE TO LOW BATTERY POWER.]	—	Management information cannot be restored due to insufficient remaining battery capacity.	A message is displayed. • Replace with a fully charged battery, or connect the AC adaptor.
[CANNOT PROTECT.]	—	This is a clip that cannot be protected.	A message is displayed. • Match the device and content versions.
[THE CLIP IS PROTECTED. PLEASE CANCEL PROTECTION.]	—	The clip is protected so it cannot be deleted.	A message is displayed. • Cancel the protect on the clip.
[CANNOT DELETE UNTIL TOP MENU IS DELETED. DELETE TOP MENU? (RECORDED DATA WILL NOT BE DELETED)]	—	It is trying to delete a clip on the SD card where the top menu is created.	A message is displayed. • Delete the top menu.
[CANNOT RECORD UNTIL TOP MENU IS DELETED. DELETE TOP MENU? (RECORDED DATA WILL NOT BE DELETED)]	—	The SD card with top menu created is inserted.	A message is displayed. • Delete the top menu.
[THUMBNAIL DATA ERROR IS DETECTED.]	—	An error occurred in the thumbnail information of the SD card.	A message is displayed. • Restoring of the management information is performed automatically after this.
[CANNOT RECORD - INCOMPATIBLE CONTROL DATA.]	—	Version of the management information of the SD card is not supported.	A message is displayed. • Match the device and content versions.
[CANNOT SET.]	—	This cannot be set.	A message is displayed. • Perform the setting after making it possible to set.
[THIS CLIP CANNOT BE COPIED.]	—	The clip cannot be copied.	A message is displayed. • Copy the clips other than the corresponding clip.
[CONTROL DATA ERROR HAS BEEN DETECTED. (SD CARD)]	—	An error occurred in the management information of the SD card.	A message is displayed. • Restoring of the management information is performed automatically after this.
[COPY FAILED. PLEASE CHECK THE CARD.]	—	Copying of the clip has failed due to an error in the SD card.	A message is displayed. • Check the SD card.
[COPY TERMINATION IN PROGRESS DUE TO INSUFFICIENT BATTERY POWER. DO NOT SWITCH OFF.]	—	Remaining battery capacity became low while copying the clip.	A message is displayed. • The copy is cancelled. • Replace with a fully charged battery, or connect the AC adaptor.
[COPY TERMINATED DUE TO INSUFFICIENT BATTERY POWER.]	—	Copying of a clip is cancelled due to insufficient remaining battery capacity.	A message is displayed. • Replace with a fully charged battery, or connect the AC adaptor.
[CANNOT COPY - THE NUMBER OF CLIPS HAS REACHED MAXIMUM.]	—	The number of clips that can be copied has reached the maximum.	A message is displayed. • Replace the SD card or delete unnecessary clips in the copy destination.
[LOW BATTERY. PLEASE CONNECT AC ADAPTOR OR CHANGE BATTERY.]	—	It is trying to copy a clip or update the camera firmware while the remaining battery capacity is insufficient.	A message is displayed. • Replace with a fully charged battery, or connect the AC adaptor.
[CANNOT PLAY THIS CLIP ON THIS MODEL.]	—	This is a clip that cannot be played back with the camera.	A message is displayed. • Playback on a device that can playback.
[Cannot copy: contains recordings from other devices.]	—	The clip recorded in other device cannot be copied.	A message is displayed. • Copy the clips other than the corresponding clip.

6. Appendix

6-4. Error and warning system

MESSAGE

Screen display		Description	Behavior and cause
VIEW screen	HOME screen		
[ERROR HAS OCCURRED. TO REPAIR THE CONTROL DATA, PLEASE CONNECT AC ADAPTOR OR CHANGE BATTERY.]	—	The remaining battery capacity was low when the restoring of the management information is started.	A message is displayed. • Replace with a fully charged battery, or connect the AC adaptor.
[INVALID.]	—	Operation is disabled.	A message is displayed. • Operate after the operation becomes enabled.
[Cannot record - Playlist capacity is full.]	—	It has tried to record on the SD card which the number of playlist that can be recorded has reached the maximum.	A message is displayed. • Replace the SD card or delete unnecessary clips.
[Cannot copy - Playlist capacity is full.]	—	It has tried to copied to the SD card which the number of playlist that can be recorded has reached the maximum.	A message is displayed. • Replace the SD card or delete unnecessary clips.
[Exceeds capacity. Please reselect.]	—	The remaining recordable capacity of the copy destination SD card is insufficient.	A message is displayed. • Reselect the clip to copy, or secure sufficient remaining recordable capacity in the copy destination SD card.
[Check the destination media.]	—	An error has occurred in the copy destination SD card while copying.	A message is displayed. • Confirm the copy destination SD card.
[NO SCENE FILE.]	—	There is no scene file in the read source SD card.	A message is displayed. • Insert an SD card that has a scene file.
[SCENE FILE LOAD FAILED]	—	Reading of the scene file has failed.	A message is displayed. • Check the SD card.
[SCENE FILE WRITE FAILED]	—	Writing of the scene file has failed.	A message is displayed. • Check the SD card.
[DISCONNECT USB CABLE.]	—	Due to an OS non-compatible error, five minutes has elapsed until the USB service mode connection is established.	A message is displayed. • Confirm if the OS in use is supported by the camera.
[CARD LOCKED.]	—	It has tried to protect or delete a clip in the locked SD card. It has tried to copy a clip to the locked SD card.	A message is displayed. • Unlock the SD card.
[CANNOT SELECT MORE CLIPS.]	—	It has tried to select more than 99 clips.	A message is displayed. • Execute the process such as copying by every 99 clips.
[SELECT THE CLIP TO BE DELETED.]	—	It has tried to delete a clip without choosing any.	A message is displayed. • Select a clip to be deleted.
[SELECT THE CLIPS TO COPY.]	—	It has tried to copy a clip without choosing any.	A message is displayed. • Select a clip to be copied.
[Insert a card in slot 1.]	—	It has tried to copy without inserting the SD card into the card slot 1.	A message is displayed. • Insert an SD card into the card slot 1.
[Insert a card in slot 2.]	—	It has tried to copy without inserting the SD card into the card slot 2.	A message is displayed. • Insert an SD card into the card slot 2.
[CHECK CARD.]	—	It has tried to copy to an error card.	A message is displayed. • Check the SD card.
[CANNOT COPY.]	—	It has tried to copy a content recorded in a AVCHD format with a different system frequency (59.94 Hz system or 50 Hz system) between the copy source SD card and the copy destination SD card.	A message is displayed. • Set the system frequency (59.94 Hz system or 50 Hz system) for the contents in the copy source SD card and the copy destination SD card to be the same. • The system frequency information for the AVCHD format is confirmed at the time of formatting or at the first recording.
[Cannot add. The number of accounts has reached maximum.]	—	Have tried to newly register a user account while maximum number of user accounts (ten accounts) are already registered.	A message is displayed. • Delete unnecessary user account.
[CANNOT RECORD.]	—	Cannot be recorded.	A message is displayed. • Perform recording after making it possible.

6. Appendix

6-5 Genuine accessories

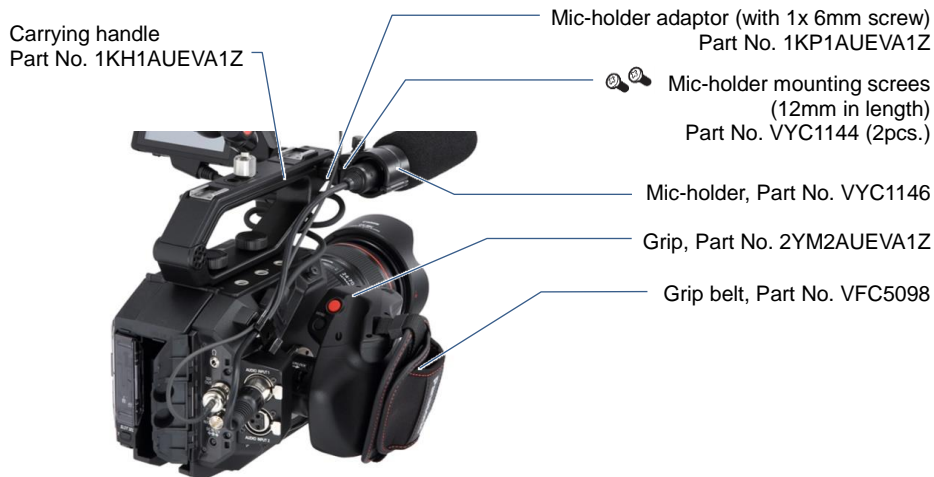

AC power cord



Part No.		
K2CA2YY00259	for AU-EVA1P, PJ	(C type plug) (BF type plug)
K2CA2YY00129	for AU-EVA1PX	
K2CR2YY00026	for AU-EVA1AN	
K2CQ2YY00117	for AU-EVA1EJ, EN	
K2CT2YY00095	for AU-EVA1EJ	
K2CP2YY00083	for AU-EVA1ED	
K2CA2YY00130	for AU-EVA1MC	

* Part number and design are subject to change without notice.

6. Appendix

AU-EVA1 Genuine accessory

Battery packs (Quick charging with AG-BRD50 charger available with AG-VBR series packs)



AG-VBR118G
(11,800mAh)



AG-VBR89G
(8,850mAh)



AG-VBR59
(5,900mAh)



VW-VBD58
(5,800mAh)

Battery charger



AG-BRD50
(Supports quick charging with
AG-VBR battery packs)

Microphone



AJ-MC200G
(+48V, XLR)

Wireless LAN module



AJ-WM50
(Supports 2.4GHz / 5GHz)

*Not available for some countries/regions

* Part number and design are subject to change without notice.

6. Appendix

6-6. Specifications

General specification

Power	DC 7.28 V (Battery Operation) DC 12 V (AC adapter operation)
Power Consumption	19 W (when using LCD monitor)
Operating Temperature	0 °C to 40 °C (32°F to 104°F)
Operating Humidity	10% to 80% (relative humidity)
Storage Temperature	-20 °C to 60 °C (-4°F to 140°F)
Weight	Body: Approx. 1.2 kg (2.65 lb) (excluding accessories) Shooting: Approx. 2.05 kg (4.52 lb) (with accessories)
Dimensions	135 mm (W) x 133 mm (H) x 170 mm (D) (excluding protrusions and accessories) (5-5/16 inches x 5-1/4 inches x 6-11/16 inches)

Camera unit

Image Sensor	Super 35 mm, MOS sensor
Number of Pixels	Total pixels: Approx. 20.49 megapixels, 6340 (H) x 3232 (V) Effective pixels: Approx. 17.25 megapixels, 5720 (H) x 3016 (V)
Sensor Area and Max Frame Rate	S35: 4K/UHD 60 fps/50 fps 2K/HD 120 fps/100 fps 4/3": 2K/HD 240 fps/200 fps
Latitude	14 stop
Log	V-Log
Gamma	eV-Look Gamma (2 types) Video Gamma Hybrid Log Gamma (HLG)
Gamut	V-Gamut (V-Log)
ISO Settings	[ISO] mode: NATIVE ISO: 800, 2500 800 Base: 200 to 2000 2500 Base: 1000 to 25600 [dB] mode: (Normal) -12 dB to 8 dB (High) -8 dB to 20 dB
Shutter Speed	[deg] mode: 3.0 deg to 357.0 deg (0.5 deg step) 12 presets [sec] mode: 1/24.1 sec to 1/8000 sec (23.98p) 12 presets
Color Temp	ATW, AWB, 2000 K to 15000 K \pm 10.0 GMg 12 presets
Lens Mount	EF mount
Image Stabilization	Electric Image Stabilization (EIS)
Auto Focus	One push auto focus
ND Filter	CLEAR, 0.6ND, 1.2ND, 1.8ND, Electrical driven
IR Cut Filter	USER assignable IR shooting (filter ON/OFF)

6. Appendix

Memory card recorder

Recording Media	SDHC memory card (4 GB to 32 GB) SDXC memory card (32 GB to 128 GB) UHS- I /UHS- II UHS Speed Class3 is supported, Video Speed Class V90 is supported
Recording Slot	SD memory card slot x 2
Recording Resolution	4096 x 2160 (4K), 3840 x 2160 (UHD), 2048 x 1080 (2K), 1920 x 1080 (FHD), 1280 x 720 (HD)
Recording System Frequency	59.94p, 50p, 29.97p, 25p, 24p, 23.98p, 59.94i, 50i
2slot Functions	Simul Rec, Relay Rec
Other Rec Functions	Pre Rec, Interval Rec

Digital video

Quantizing	MOV: 4:2:2 10 bit/4:2:0 8 bit AVCHD: 4:2:0 8 bit
Video Compression Format	H.264/MPEG-4 AVC High Profile

Digital audio

Recording Audio Format	MOV: 48 kHz/24 bit, 2 CH, Linear PCM AVCHD: 48 kHz/16 bit, 2 CH, Dolby Audio™
Headroom	18 dB/20 dB (menu switchable)

6. Appendix

Video output

SDI OUT	<p>0.8 V [p-p], 75 Ω, 4K (6G), HD (3G/1.5G) Output format (4:2:2 10 bit):</p> <ul style="list-style-type: none">• 4096 x 2160: 29.97p, 25p, 24p, 23.98p• 3840 x 2160: 29.97p, 25p, 24p, 23.98p• 1920 x 1080: 59.94p, 50p, 59.94i, 50i, 29.97p, 29.97PsF, 25p, 25PsF, 24p, 24PsF, 23.98p, 23.98PsF• 1280 x 720p: 59.94p, 50p <p>RAW output format (10 bit):</p> <ul style="list-style-type: none">• 5760 x 3072: 29.97p, 25p, 24p, 23.98p• 4096 x 2160: 59.94p, 50p, 29.97p, 25p, 24p, 23.98p• 2048 x 1080: 59.94p, 50p, 29.97p, 25p, 24p, 23.98p
HDMI	<p>HDMI x 1, TypeA, HDMI REC REMOTE is supported, Viera Link is NOT supported Output format (4:2:2 10 bit):</p> <ul style="list-style-type: none">• 4096 x 2160: 59.94p, 50p, 29.97p, 25p, 24p, 23.98p• 1920 x 2160: 59.94p, 50p, 29.97p, 25p, 24p, 23.98p• 1920 x 1080: 59.94p, 50p, 59.94i, 50i, 29.97p, 25p, 24p, 23.98p• 1280 x 720: 59.94p, 50p• 720 x 480: 59.94p• 720 x 576: 50p <p>Output format (4:2:0 8 bit):</p> <ul style="list-style-type: none">• 4096 x 2160: 59.94p, 50p• 3840 x 2160: 59.94p, 50p

Audio in/out

Internal Mic	Stereo microphone
INPUT1/2	XLR (3-pin) x 2 (INPUT1/2), input high impedance, LINE/MIC/MIC +48 V (menu switchable) MIC: -40 dBu/-50 dBu/-60 dBu (menu switchable) LINE: +4 dBu/0 dBu (menu switchable)
SDI OUT	Linear PCM 2 CH
HDMI	Linear PCM 2 CH
PHONES	3.5 mm stereo mini jack x 1
Speaker	20 mm diameter, round x 1

Other in/out

TC IN/OUT	BNC x1 for IN/OUT (menu switchable) IN: 1.0 V [p-p] to 4.0 V [p-p], 10 kΩ OUT: 2.0 V [p-p] ±0.5 V [p-p], low impedance
LCD	40-pin (Dedicated)
REMOTE	2.5 mm Super Mini Jack
USB 2.0 (HOST)	Type-A, 4-pin for Wireless Module (Optional)
EF Mounting Contact	8-pin
DC IN 12 V	DC 12 V EIAJ type 4

6. Appendix

LCD monitor

Size	3.5-type LCD monitor (approx. 1,150,000 dots) Touch panel (MENU control, Shooting assist functions)
Switches	MIRROR (OFF, B/T, ROTATE)

Hand grip

Mounting	One touch rotatable/Detachable
Mechanism	
Switches	REC, MENU.MENU/IRIS multifunctional dial, User switch x 2

Accessories comes standard

Accessories	Battery (5900mAh), Battery charger, AC adapter, AC cable, Shoulder strap, Microphone holder, Microphone holder adapter, LCD monitor (with hood and mounting attachment), Handle, Grip, Grip belt, Mount cap
-------------	---

* Dolby, Dolby Audio, and the double-D symbol are trademarks of Dolby Laboratories.

* Specifications are subject to change without notice.

6. Appendix

6-7. Dimensions

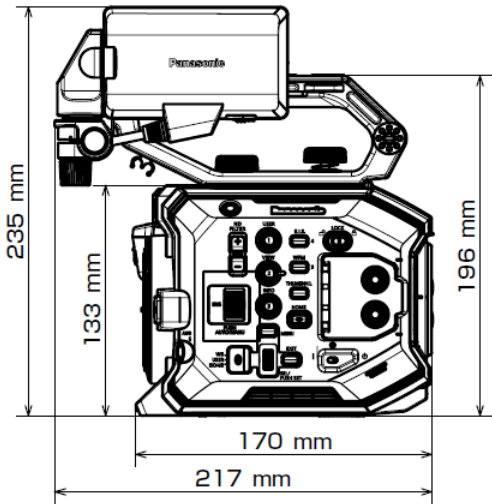
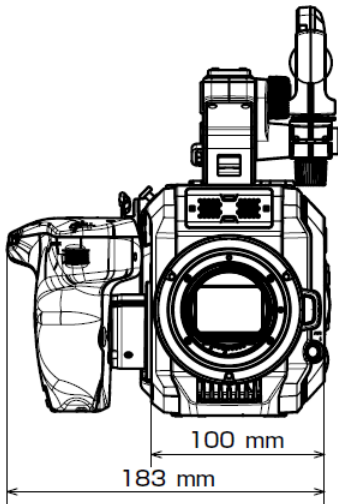
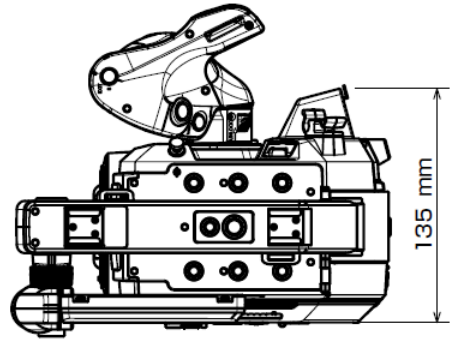

Revision history

Issued	History	Document Version
Jan 2018	First edition issued	V1.00E
Apr 2018	Added description of new features, available since firmware version 2.02.	V2.00E

Panasonic

Panasonic Corporation

Download firmware, check frequently asked questions for the AU-**EVA1** at
https://panasonic.biz/cns/sav/pass_e